



Low voltage AC drives

ABB industrial drives ACS800, drive modules 0.55 to 2900 kW Catalog

Selecting and ordering your drive

Build up your own ordering code using the type designation key below or contact your local ABB drives sales office and let them know what you want. Use page 3 as a reference section for more information.

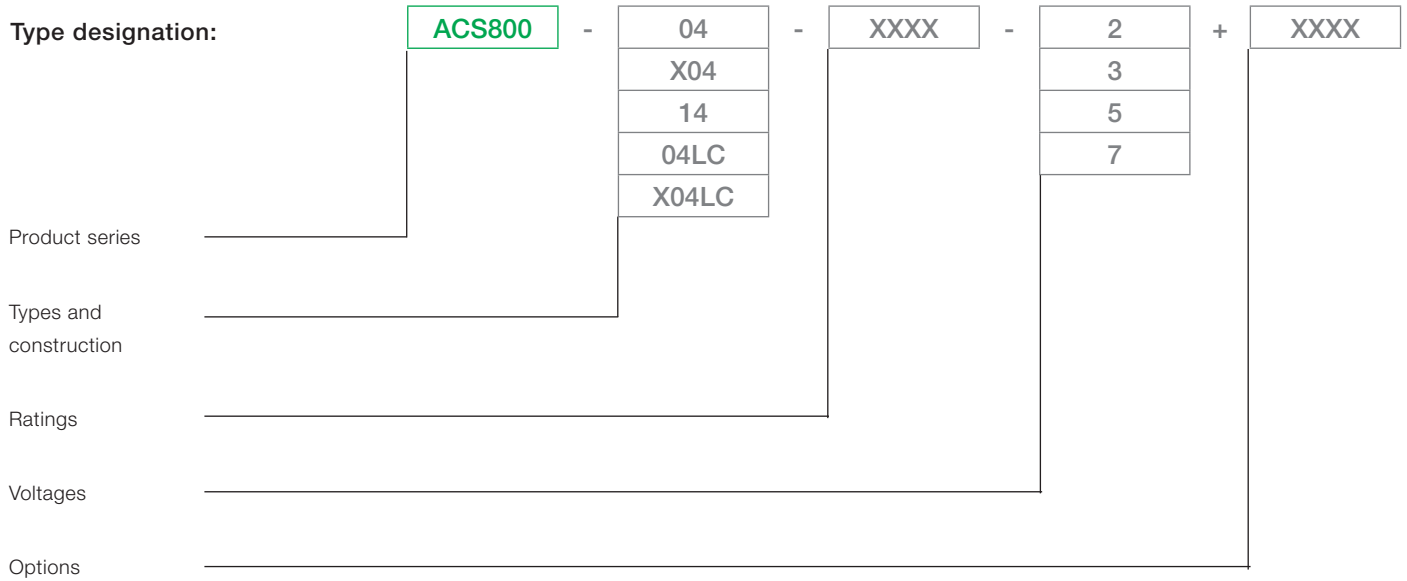

Contents

ABB industrial drives, drive modules

ABB industrial drives	4
Drive modules main features	6
Technical data	8
Single drive modules, ACS800-04/-04M/-14	10
ACS800-04, -04M	14
ACS800-14	18
Multidrive modules, ACS800-x04	19
Liquid-cooled modules, ACS800-04LC/-x04LC	27
ACS800-04LC	28
ACS800-x04LC	29
Brake options	33
EMC filters	39
Sine filters	40
du/dt filters	42
Standard user interface	44
Standard I/O	44
Options	45
Control panel	45
Optional I/O	46
Fieldbus control	47
Remote monitoring and diagnostics tool	48
Standard control program	49
Optional control programs	50
Control solutions for different applications	51
DriveSize, dimensioning tool	53
DriveWindow, start-up and maintenance tool	54
DriveAP, programming tool	55
DriveAnalyzer, start-up and maintenance tool	56
DriveOPC, integration tool	57
Summary of features and options table	58
Services	61

ABB industrial drives



ABB industrial drives

ABB industrial drives are designed for industrial applications, and especially for applications in process industries such as the pulp and paper, metals, mining, cement, power, chemical, and oil and gas industries. ABB industrial drives are highly flexible AC drives that can be configured to meet the precise needs of these applications, and hence order-based configuration is an integral part of the offering. These drives cover a wide range of powers and voltages, including voltages up to 690 V. ABB industrial drives come with a wide range of built-in options. A key feature of these drives is programmability, which makes adaptation to different applications easy.

Industrial design

ABB industrial drives are designed with current ratings to be used in industrial environments for applications requiring high overloadability. The heart of the drive is DTC, direct torque control, that provides high performance and significant benefits: e.g. accurate static and dynamic speed and torque control, high starting torque and long motor cables. Built-in drive options make the installation work fast and easy.

One of the most significant design criteria of ABB industrial drives has been the long lifetime. Wearing parts such as fans and capacitors have been selected accordingly. Together with the extensive protection features this results in excellent reliability in the demanding industrial market.

Drive modules

Drive modules are designed to be built into a customer's own cabinet. The modules typically have an IP00 or IP20 enclosure class. ABB's module package also includes cabinet assembly documentation.

Type designation

This is the unique reference number that clearly identifies your drive by construction, power rating voltage and selected options. Using the type designation you can specify your drives from the wide range of options available, customer specific options are added to the type designation using the corresponding + code.

ABB's module offering - common features

ABB industrial drive modules are meant for system integrators and/or machine builders who are making their own applications, which include the cabinet structure as well as the software features needed.

ACS800 modules include everything that is required for a complete drive, there is always a built-in harmonic filtering choke, for example. There is also a wide selection of built-in options such as EMC filtering and different I/O and communication options. In addition to these a selection of external accessories is also available. All the modules can be mounted side by side.

In addition to the modules being designed for cabinet assembly, cabinet assembly documentation is included. The documentation gives examples of different cabinet installations, examples of drawings, and hints on the selection of auxiliary equipment. The flexibility and programmability of the modules makes them very viable for various application needs in different areas of industry.

Functional safety

The ABB functional safety solution complies with the requirements of the European Union machinery directive 2006/42/EC. This directive is associated with standards such as IEC 62061 (Safety Integrity Level) and ISO 13849-1 (Performance Level), which require both a documented and proven safety performance and life cycle approach to safety. Safe torque-off is a certified solution offering SIL2 and PL d (Cat.2) safety levels.

ABB drives can be provided, as an option, with the safe torque-off function. Safe torque-off can be used for the prevention of unexpected start-up and represents a cost-effective and certified solution for basic safety. Other safety functions include safe stop 1 (SS1) and safely-limited speed (SLS), which can be used to achieve SIL2 or PL d (Cat.3) safety levels.

Other products:
Please also see the separate catalogs
ACS800 multidrives, code 3AFE68248531 EN,
ACS800 single drives, code 3AFE68375126 EN.

ACS800-X4 single drive modules

ACS800-X4 units are complete single drive module products that are optimised for assembly in customers' own cabinets.

The single drive configuration contains a rectifier, DC link and an inverter in one single AC drive unit.

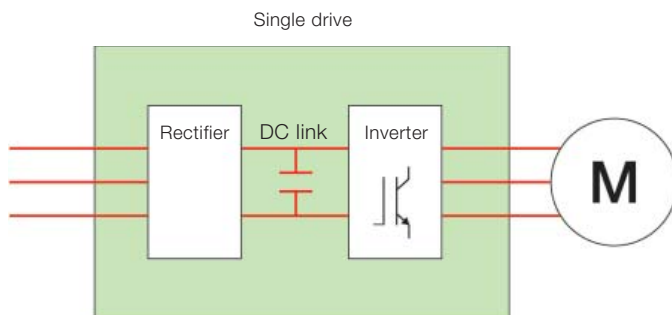

The ACS800-X4 is designed to minimise the amount of cabinet space used and to make cabinet assembly as easy as possible. The power range is from 0.55 to 1900 kW.

ACS800-X04 multidrive modules

The multidrive principle is based on a standard DC bus arrangement enabling single power entry and common braking resources for several drives. There are several possibilities on the supply side starting from a simple diode supply unit up to highly sophisticated IGBT supply units.

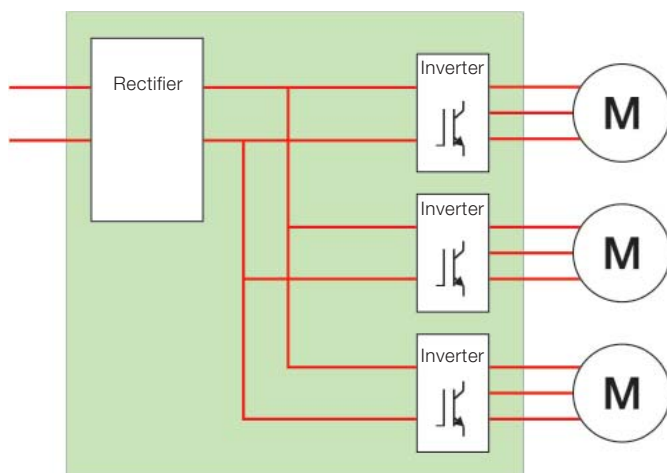

The multidrive construction simplifies the total installation and provides many advantages such as:

- Savings in cabling, installation and maintenance costs
- Space savings
- Reduced component count and increased reliability
- Reduced line currents and simpler braking arrangements
- Energy circulation over the common DC busbar, which can be used for motor-to-motor braking without the need for a braking chopper or regenerative supply unit.
- The common supply of the multidrive enables the implementation of overall safety and control functions.

With their compact and modular design and wide range of powers, voltages and options, ABB multidrive modules offer optimised and simple cabinet installation. The power range is from 1.1 to 2900 kW.

Liquid-cooled modules

The ACS800 liquid-cooled drive modules with direct liquid cooling and robust design are an ultimate solution for various applications where space savings and silent operation is a must.

Since the coolant takes care of 98% of the heat losses, no additional filtered air-cooling is needed.

This decreases the noise level and increases the total efficiency of the converter installation. The high-efficiency liquid cooling removes the need for air-conditioning in the installation rooms, bringing

the installation and operation costs down. The possibility to have totally enclosed cabinet structure makes the ACS800 liquid-cooled drive modules perfect for harsh environmental conditions.

The ACS800 liquid-cooled multidrive modules are available from 1.1 to 2240 kW at 380 to 690 V supply voltage while the ACS800 liquid-cooled single drive modules from 200 to 2240 kW at 380 to 690 V supply voltage.

Drive modules main features

Feature	Advantage	Benefit
Compact and complete		
Compact size, everything integrated	Less space and installation work required.	No need to install extra components such as input chokes or EMC filter. Possibility for side by side mounting.
Built-in harmonic filter in all ACS800 drives	Low harmonics, meaning less interference and less heating in cables and transformers. Filter also protects the drive from line side transients. Easier installation due to lower number of components.	
Wide range of options available	Standard solutions available from ABB that meets most of the customer needs.	
Versatile braking options	Always the optimal braking option available. In most types no need for external braking chopper thus reducing size and installation cost.	Brake chopper built-in in all frame sizes (standard/optional).
Optimised products for cabinet assembly	Possible to use any kind of customer specific cabinet. Easy to make the cabinet assembly saving time and money.	
User interface		
User-friendly customer interface	Easy and fast commissioning and operation.	Control panel has clear, alphanumeric display with start-up assistant that guides through the start-up procedure. Easy to use PC tools available for commissioning, maintenance, monitoring and programming.
Versatile connections and communications	Standard I/O covers most requirements. Connectable to commonly used fieldbuses.	Extensive standard and optional I/O. I/O fulfills PELV (EN 50178).
Extensive programmability	Flexibility. Possible to replace relays or even PLC in some applications.	Two levels of programmability: 1. Parameter programming (standard) 2. Adaptive programming (free block programming) <ul style="list-style-type: none"> - Standard feature - More blocks available as options - All I/Os are programmable
Industrial design		
Wide power and voltage range	One product series suits everywhere meaning less training and fewer spare parts, and a standardised interface to drives.	
Galvanic isolation of I/O	Safe and reliable operation without separate isolators and relays.	Isolated input signals and relay outputs as standard.

Drive modules main features

Feature	Advantage	Benefit
Industrial design		
Robust main circuit design	Suitable for heavy industrial use. Reliable. Long motor cables can be used without extra output filters.	Components dimensioned for heavy duty and long lifetime. Advanced thermal model allows high overloadability.
Extensive protections	Enhanced reliability, fewer process interruptions. Possibility to also protect motors and process.	Several adjustable limits to protect other equipment also.
Functional safety	Certified safety features according to Machinery Directive 2006/42/EC. Safe operation and maintenance.	Safe torque-off available as built-in option.
All terminals designed for industrial use	Adequate size even for large aluminium cables. No need for special tools in I/O cabling.	
Worldwide approvals: CE, UL, cUL, CSA, C-Tick, GOST R	Safe products that can be used everywhere in the world.	
Right performance for every application		
DTC, accurate dynamic and static speed and torque control	Excellent process control even without pulse encoder - improved product quality, productivity, reliability and lower investment cost.	
DTC - allows high overloadability and gives high starting torque	Reliable, smooth start without overdimensioning the drive.	
DTC, fast control	No unnecessary trips and process interruptions.	Fast reaction to load or voltage variations prevents tripping. Rides through power interruptions by using kinetic energy of the load.
DTC, flux optimization and sophisticated motor model	Excellent motor and drive efficiency - cost savings.	Optimal flux in the motor reduces losses.
DTC, mechanics friendly	Less stress for mechanics improves reliability.	No shock torques. No torque ripple - minimized risk for torsional vibration. Active oscillation damping.
Both positioning / synchronizing control and normal speed / torque control available in the same hardware	Same hardware and similar user interface for different applications meaning less training and fewer spare parts as well as easier system design and documentation.	
Made in ABB		
Global market leader in AC drives. Long experience.	Well proven, safe and reliable solutions. Application know-how.	
World wide service and support network	Professional support available around the world.	

Technical data



Mains connection	
Supply voltage	3-phase, $U_{2IN} = 208$ to 240 V, $\pm 10\%$, except multidrive and nxR8i ACS800-04 modules 3-phase, $U_{3IN} = 380$ to 415 V, $\pm 10\%$ 3-phase, $U_{5IN} = 380$ to 500 V, $\pm 10\%$ 3-phase, $U_{7IN} = 525$ to 690 V, $\pm 10\%$
Frequency	48 to 63 Hz
Power factor	$\cos\phi_1 = 0.98$ (fundamental) $\cos\phi = 0.93$ to 0.95 (total)
Power factor ISU	$\cos\phi_1 = 1$ (fundamental) $\cos\phi = 0.99$ (total)
Efficiency (at nominal power)	
ACS800-04	98%
ACS800-X04	98%
	97% with IGBT supply unit
Motor connection	
Voltage for > 500 V units	3-phase output voltage 0 to $U_{2IN}/U_{3IN}/U_{5IN}/U_{7IN}$ please see "Filter selection table for ACS800" under the du/dt filters on page 42
Frequency	0 to ± 300 Hz 0 to ± 300 Hz, also with built-in du/dt filters in R8i module. (0 to ± 120 Hz with external du/dt filters in R2i to R7i)
Field weakening point	8 to 300 Hz
Motor control	ABB's direct torque control (DTC)
Torque control:	Torque step rise time:
Open loop	<5 ms with nominal torque
Closed loop	<5 ms with nominal torque
	Non-linearity:
Open loop	$\pm 4\%$ with nominal torque
Closed loop	$\pm 3\%$ with nominal torque
Speed control:	Static accuracy:
Open loop	10% of motor slip
Closed loop	0.01% of nominal speed
	Dynamic accuracy:
Open loop	0.3 to 0.4% sec. with 100% torque step
Closed loop	0.1 to 0.2% sec. with 100% torque step

Environmental limits	
Ambient temperature	
Transport	-40 to +70 °C
Storage	-40 to +70 °C
Operation	
ACS800-04	-15 to +50 °C, no frost allowed 40 to 50 °C at reduced output current (1% / 1 °C)
ACS800-04 nxR8i, -X04, -14	0 to +50 °C, no frost allowed 40 to 50 °C at reduced output current (1% / 1 °C)
Cooling method:	Dry clean air
Altitude	
0 to 1000 m	Without derating
1000 to 4000 m	With derating ~ (1% / 100 m) (690 V units 1000 to 2000 m with derating)
Relative humidity	5 to 95%, no condensation allowed
Protection class	
IP00	Standard for -04 and 04(M) frame sizes R7, R8 and nxR8i
IP20	Standard for -04 frame sizes R2 to R6 and option for some -04(M) variants
Paint colour	NCS 1502-Y (RAL 9002, PMS 420 C)
Contamination levels	No conductive dust allowed
Storage	IEC 60721-3-1, class 1C2 (chemical gases), Class 1S2 (solid particles)
Transportation	IEC 60721-3-2, Class 2C2 or 3C2* (chemical gases), Class 2S2 (solid particles)
Operation	IEC 60721-3-3, Class 3C2 (chemical gases), Class 3S2 (solid particles without airinlet filters)
	C = chemically active substances S = mechanically active substances * = coated circuit boards

Product compliance	
	CE, UL, cUL, CSA; C-Tick and GOST R
	Low Voltage Directive 2006/95/EC
	Machinery Directive 2006/42/EC
	EMC Directive 2006/108/EC
	Quality assurance system ISO 9001 and Environmental system ISO 14001

EMC according to EN 61800-3	
	2 nd environment, unrestricted distribution category C3 - as option in ACS800-04 up to frame size R8
	1 st environment, restricted distribution category C2 as option up to 1000 A input current
	Available options are shown in the summary of features and options table. Please see pages 58-60.

Technical data



Mains connection	
Supply voltage	3-phase $U_{3IN} = 380$ to 415 V, $\pm 10\%$ 3-phase $U_{5IN} = 380$ to 500 V, $\pm 10\%$ 3-phase $U_{7IN} = 525$ to 690 V, $\pm 10\%$
Frequency	48 to 63 Hz
Power factor	$\cos\phi_1 = 0.98$ (fundamental) $\cos\phi = 0.93$ to 0.95 (total)
Efficiency (at nominal power)	> 98%
Motor connection	
3-phase supply voltage	Output voltage: 0 to $U_{3IN} / U_{5IN} / U_{7IN}$
Frequency	0 to ± 300 Hz
Field weakening point	8 to 300 Hz
Motor control	ABB's direct torque control (DTC)
Torque control:	Torque step rise time:
Open loop	<5 ms with nominal torque
Closed loop	<5 ms with nominal torque
	Non-linearity:
Open loop	$\pm 4\%$ with nominal torque
Closed loop	$\pm 3\%$ with nominal torque
Speed Control:	Static accuracy:
Open loop	10% of motor slip
Closed loop	0.01% of nominal speed
	Dynamic accuracy:
Open loop	0.3 to 0.4% sec. with 100% torque step
Closed loop	0.1 to 0.2% sec. with 100% torque step
Enclosure	
IP class	IP00
Paint color module front	Light beige RAL 7035

Environmental limits	
Ambient temperature	
Transportation	-40 to +70 °C
Storage	-40 to +70 °C
Operation in totally enclosed cabinet	0 to 55 °C, no frost allowed 45 to 55 °C at reduced output power (0.5% / 1 °C)
Relative humidity	5 to 95%, no condensation allowed
Vibration	0.7 g, 13.2 Hz to 100 Hz, 1 mm displacement 2 to 13.2 Hz
Cooling Method	Liquid-cooled, closed loop
Internal cooling circuit	Drinking water +42 °C max, 42 to 48 °C at reduced output power (1.0% / 1 °C)
External cooling circuit with optimal liquid cooling unit	Industrial or sea water +38 °C max, 38 to 45 °C at reduced output power (1.0% / 1 °C)
Altitude	
0 to 1000 m	Without derating
1000 to 4000 m	With derating ~ (1% / 100 m) (690 V units 1000 to 2000 m with derating)
Storage	IEC 60721-3-1, class 1C2 (chemical gases), Class 1S2 (solid particles)
Transportation	IEC 60721-3-2, Class 2C2 or 3C2* (chemical gases), Class 2S2 (solid particles)
Operation	IEC 60721-3-3, Class 3C2 (chemical gases), Class 3S2 (solid particles without air inlet filters)
C = chemically active substances S = mechanically active substances * = coated circuit boards	

Product compliance	
CE, UL, CSA, GOST-R	
Low Voltage Directive 2006/95/EC	
Machinery Directive 2006/42/EC	
EMC Directive 2006/108/EC	
Quality assurance system ISO 9001 and	
Environmental system ISO 14001	

EMC according to EN 61800-3	
2 nd environment, unrestricted distribution category C3 - as option in ACS800-04 up to frame size R8	
1 st environment, restricted distribution category C2 as option up to 1000 A input current	

Single drive modules

ACS800-04/-04M/-14

ACS800-04 single drive modules

ACS800-04 drives are single drive modules that are optimised for building into customers' own cabinets. They have been designed to minimise the cabinet space used, make cabinet assembly as easy as possible, and give maximum flexibility. The power range is from 0.55 to 1900 kW. All the drives, regardless of the power and voltage, have the same customer interface and I/O making system design and training easier.

The units have everything necessary built-in. That includes, for example, built-in chokes for harmonic filtering as standard, built-in braking chopper and built-in EMC filtering (both are optional in some frame sizes), making cabinet assembly easier. There is also a wide selection of different I/O and communications options.

In addition to these there is a selection of external accessories available.

To optimise the use of the cabinet space, most of the ACS800-04 modules can be mounted side by side. The modules themselves are not only designed for cabinet assembly, but covering documentation is also available. This documentation provides examples of different cabinet installations and circuit drawings, and hints on the selection of auxiliary equipment.

Optimised for cabinet assembly - frame sizes R2 to R6

The R2 to R6 frame size units are designed for cabinet wall mounting. The power range starts from 0.55 kW and extends up to 200 kW. The voltage range is from 230 to 690 V. The enclosure class of the modules is IP20 as standard.

Flange mounting is available as an option. It separates the airflow to the control section and the heatsink, and makes it possible to mount the heatsink of the drive outside the enclosure. With this option the heatsink side of the module has IP55 enclosure class. Safe torque-off (complies with the European Union machinery directive 2006/42/EC) is also available as option.

Compact power - frame sizes R7 and R8

Frame size R7 and R8 modules have a very narrow bookshelf design. They are designed to be mounted either on the cabinet wall or floor. The power range is from 45 to 560 kW and the voltage range is from 230 to 690 V. The enclosure class is IP00.

The modules have top entry for the input power connections to optimise the use of space and cable routing in the cabinet.

The output power connections are on the side to make access to the cables as easy as possible and to give sufficient space for cable bending. The outputs can be placed either on the left or right hand side of the module. I/O connections can be located in the most optimal place in the cabinet as they are in a separate unit.



Single drive modules

ACS800-04/-04M/-14

Ultimate flexibility - ACS800-04M variant with frame sizes R7 and R8

The ACS800-04M is similar in many respects to the frame size R7 and R8 ACS800-04, but it has even more variants available. For this reason the configuration rules are also different. In addition to the normal bookshelf mounting, the ACS800-04M also offers flat (sideways) mounting as an alternative for installations where the available depth inside the cabinet is limited. In frame size R7 the ACS800-04M also offers a version where the motor connections are from the bottom of the module. This makes it possible to use a narrower cabinet in some installations.

In addition to the normal IP00 enclosure, the ACS800-04M offers also IP20 as an option for some mounting variants. Safe torque-off (complies with the European Union Machinery Directive 2006/42/EC) is also available as option.



High ratings - frame sizes D4 to n*D4 supply side and n*R8i inverter units

The construction includes separate IP00 enclosure supply and inverter modules. The modules are of the extremely compact bookshelf design, making the width of the drive very competitive. The wheels in every module make manoeuvring very easy. Modules are also connected to the separate cabling part by quick connectors, enabling each module to be pulled out quickly and easily by just disconnecting a couple of bolts without the need to disconnect any cables. The inverter modules and supply modules are parallel connected.

Supply units have load switch as standard; a contactor is also available as a built-in option. The supply module structure is designed to be either 6-pulse or 12-pulse.

The control unit and I/O connections can be located in the most optimal place in the cabinet as they are in a separate unit.

The power range for these higher rated ACS800-04 packages is from 400 to 1900 kW, and the voltage range is from 380 to 690 V.

Main standard hardware features:

Common:

- Optimised design for cabinet assembly
- Easy access to power terminals
- Compact design
- Side by side mounting (excl. versions with side exit)
- Harmonic filtering choke inside
- Long lifetime cooling fan and capacitors
- Extensive, programmable I/O with galvanically isolated inputs
- Three I/O and fieldbus extension slots inside
- Large power terminals allowing use of a wide range of cable sizes
- Block programming possibility

Frame sizes R2 to R6:

- Power range 0.55 to 200 kW
- Voltage range 230 to 690 V
- Mounting on the cabinet wall
- IP20 enclosure class
- Built-in brake chopper (R2 to R3; at 690 V also R4)
- Easy access to I/O terminals (control board inside the module)

Single drive modules

ACS800-04/-04M/-14

Frame sizes R7 and R8:

- Power range 45 to 560 kW
- Voltage range 230 to 690 V
- Mounting on the cabinet wall or floor
- IP00 enclosure class
- Input power cable connection from the top for optimising cabinet size and cabling inside cabinet
- Motor cable connection on the side of the module (side selectable) for maximized flexibility and optimised cabinet design (with ACS800-04M, frame size R7, bottom exit can also be selected)
- Modular design allowing a wide variety of variants
- Free location and easy access of I/O terminals (control board outside the module)
- Instructions available for installing modules in Rittal TS8 cabinet

Frame sizes nxD4 + nXR8i:

- Power range 400 to 1900 kW
- Voltage range 380 to 690 V
- Mounting on the cabinet floor
- IP00 enclosure class
- Wheels to make module manoeuvring easy
- Load switch
- du/dt filters inside of the module
- Common mode filters for motor protection
- Plug connector mechanical kits
- Free location and easy access of I/O terminals (control board outside the module)

Options for ACS800-04

Built-in options:

- Analogue and digital I/O extension modules
- Fieldbus modules
- Pulse encoder interface module
- Motion control and other control solution software
- Safe torque-off
- Control panel

Options for frame sizes R2 to R6:

- Built-in brake chopper (R4 to R6)
- EMC filter for 2nd environment, unrestricted distribution according to EN 61800-3 (Category C3)
- EMC filter for 1st environment, restricted distribution according to EN 61800-3 (Category C2)
- Flange mounting (except not for -0205-3 and -0255-5)

Options for frame sizes R7 and R8:

- Built-in brake chopper
- IP20 enclosure class (for some -04M mounting variants)
- EMC filter for 2nd environment, unrestricted distribution according to EN 61800-3 (Category C3)
- EMC filter for 1st environment, restricted distribution according to EN 61800-3 (Category C2) (-04M only requires also EMC enclosure)
- Bottom exit of motor cables (frame size R7 -04M only)
- Flat (= sideways) mounting (-04M only)
- Various output busbar options (ACS800-04M)
- Common mode filters for motor protection

Options for frame sizes nxD4 + nXR8i:

- Brake chopper module
- Built-in contactor

Examples of external options:

- Control panel and mounting platform
- Brake resistor
- Output filters
- Ethernet module
- Control panel mounting platform for cabinet door or inside the cabinet
- Front-end AC fuses (n*R8i only)
- Air circuit breaker (n*R8i only)
- DC-fuses, fuse bases, mechanical kits (n*R8i only)
- Mechanical accessories in Rittal TS8 (n*R8i only)
 - IP21 to IP54 cabinet door / roof mechanical kits
 - Mechanical cabinet accessories kits

Single drive modules

ACS800-04/-04M/-14

ACS800-14 single drive modules

The ACS800-14 drives are regenerative single drive modules equipped with active supply unit. They are full performance regenerative drives in a compact package. All important features and options including LCL line filter module(s), IGBT supply module(s), inverter module(s), common mode filters are in the package. The power range is from 75 to 1700 kW. All the drives, regardless of the power and voltage, have the same customer interface and I/O, making system design and training easier.

Main standard hardware features

- Frame sizes R7i to n*R8i control board outside of the module
- Extensive, programmable I/O
- Three I/O and fieldbus extension slots
- Inputs galvanically isolated
- Optimised design for cabinet assembly
- Modular design allowing wide variety of variants
- Compact design
- Long lifetime cooling fan and capacitors
- du/dt filters as standard in parallel connected R8i and in single or parallel connected 690 V inverter units
- Mounting on the cabinet wall frame size R7i and on the cabinet floor for R8i
- Wheels and plug connectors in the R8i inverter, and coated boards

Main optional hardware features

Inverter frame size R7i:

- Prevention of unexpected start-up
- DC fuses, fuse bases or DC-fuse switch
- Assembly plates for R7i units
- du/dt filters
- Common mode filter for motor protection -on-off control for cooling fan with internal charging option

Inverter frame sizes R8i to n*R8i:

- Prevention of unexpected start-up
- DC fuses, fuse bases or DC-fuse switch + charging circuitry -du/dt filters as options in 400 / 500 V
- Mechanical accessories in Rittal TS8 cabinets
 - IP21 to IP54 cabinet door / roof mechanical kits
 - Accessories kits
- Common mode filters for motor protection



Ratings, types and voltages

ACS800-04, single drive modules, $U_N = 230\text{ V}$

ACS800 - 04 - XXXX - 2 + XXXX

Nominal ratings		No-overload use	Light-overload use		Heavy-duty use		Noise level	Heat dissipation	Air flow	Type designation	Frame size
$I_{\text{cont. max}}$ A	I_{max} A	$P_{\text{cont. max}}$ kW	I_N A	P_N kW	I_{hd} A	P_{hd} kW	dBA	W	m ³ /h		
$U_N = 230\text{ V}$ (Range 208 to 240 V). The power ratings are valid at nominal voltage 230 V.											
5.1	6.5	1.1	4.7	0.75	3.4	0.55	62	100	35	ACS800-04-0001-2	R2
6.5	8.2	1.5	6	1.1	4.3	0.75	62	100	35	ACS800-04-0002-2	R2
8.5	10.8	1.5	7.7	1.5	5.7	1.1	62	100	35	ACS800-04-0003-2	R2
10.9	13.8	2.2	10.2	2.2	7.5	1.5	62	120	35	ACS800-04-0004-2	R2
13.9	17.6	3	12.7	3	9.3	2.2	62	140	35	ACS800-04-0005-2	R2
19	24	4	18	4	14	3	62	160	69	ACS800-04-0006-2	R3
25	32	5.5	24	5.5	19	4	62	200	69	ACS800-04-0009-2	R3
34	46	7.5	31	7.5	23	5.5	62	250	69	ACS800-04-0011-2	R3
44	62	11	42	11	32	7.5	62	340	103	ACS800-04-0016-2	R4
55	72	15	50	11	37	7.5	62	440	103	ACS800-04-0020-2	R4
72	86	18.5	69	18.5	49	11	65	530	250	ACS800-04-0025-2	R5
86	112	22	80	22	60	15	65	610	250	ACS800-04-0030-2	R5
103	138	30	94	22	69	18.5	65	810	250	ACS800-04-0040-2	R5
141	164	37	132	37	97	30	65	1190	405	ACS800-04-0050-2	R6
166	202	45	155	45	115	30	65	1190	405	ACS800-04-0060-2	R6
202	282	55	184	55	141	37	65	1440	405	ACS800-04-0070-2	R6
214	326	55	211	55	170	45	71	2900	540	ACS800-04(M)-0080-2	R7
253	404	75	248	75	202	55	71	3450	540	ACS800-04(M)-0100-2	R7
295	432	90	290	90	240 ⁴⁾	55	71	4050	540	ACS800-04(M)-0120-2	R7
405	588	110	396	110	316	90	72	5300	1220	ACS800-04(M)-0140-2	R8
447	588	132	440	132	340	90	72	6100	1220	ACS800-04(M)-0170-2	R8
528	588	160	516	160	370	110	72	6700	1220	ACS800-04(M)-0210-2	R8
613	840	160	598	160	480	132	72	7600	1220	ACS800-04(M)-0230-2	R8
693	1017	200	679	200	590 ²⁾	160	72	7850	1220	ACS800-04(M)-0260-2	R8
720	1017	200	704	200	635 ³⁾	200	72	8300	1220	ACS800-04(M)-0300-2	R8

Enclosure

Degree of protection:

IP00 standard for 04 and 04(M) frame sizes R7, R8 and nxR8I

IP20 standard for -04 frame sizes R2 to R6, option for some 04(M) variants

Paint color: RAL 9002/PMS 420C

Dimensions

Frame size	Height mm	Width mm	Depth mm	Weight kg
R2	370	165	193 ⁶⁾	8
R3	420	173	232 ⁶⁾	13
R4	490	240	253 ⁶⁾	24
R5	602	265	276	32
R6	700	300	399	64
R7	1121/1152/1126 ⁷⁾	427/632/264 ⁷⁾	473/259/467 ⁷⁾	100
R8	1564/1596 ⁸⁾	562/779 ⁸⁾	568/403 ⁸⁾	205

Nominal ratings	
$I_{\text{cont. max}}$	Rated current available continuously without overloadability at 40 °C.
I_{max}	Maximum output current. Available for 10 s at start, otherwise as long as allowed by drive temperature. Note: max. motor shaft power is 150% P_{hd} .
Typical ratings: No-overload use	
$P_{\text{cont. max}}$	Typical motor power in no-overload use.
Light-overload use	
I_N	Continuous current allowing 110% I_N for 1 min / 5 min at 40 °C.
P_N	Typical motor power in light-overload use.
Heavy-duty use	
I_{hd}	Continuous current allowing 150% I_{hd} for 1 min / 5 min at 40 °C.
P_{hd}	Typical motor power in heavy-duty use.

The current ratings are the same regardless of the supply voltage within one voltage range.

The ratings apply at 40 °C ambient temperature. At higher temperatures (up to 50 °C) the derating is 1% / 1 °C.

Notes:

- 50% overload available if $T_{\text{amb}} < 25\text{ °C}$. If $T_{\text{amb}} = 40\text{ °C}$, max overload is 37%.
- 50% overload available if $T_{\text{amb}} < 30\text{ °C}$. If $T_{\text{amb}} = 40\text{ °C}$, max overload is 40%.
- 50% overload available if $T_{\text{amb}} < 20\text{ °C}$. If $T_{\text{amb}} = 40\text{ °C}$, max overload is 30%.
- 50% overload available if $T_{\text{amb}} < 35\text{ °C}$. If $T_{\text{amb}} = 40\text{ °C}$, max overload is 45%.
- Higher value available if output frequency is above 41 Hz.
- Please note that use of control panel or I/O extension or communication options increases the depth.
- Bookshelf (in ACS800-04M +H354) / flat (+H360) / bottom exit (+H352) version.
- Bookshelf (in ACS800-04M +H354) / flat (+H360) mounting.
- Single module only.
- Cable connections need additional space (about 200 mm) behind the module.

Ratings, types and voltages

ACS800-04, single drive modules, $U_N = 400\text{ V}$

ACS800 - 04 - XXXX - 3 + XXXX

Nominal ratings		No-overload use	Light-overload use	Heavy-duty use		Noise level	Heat dissipation	Air flow	Type designation	Frame size	
$I_{\text{cont. max}}$ A	I_{max} A	$P_{\text{cont. max}}$ kW	I_N A	P_N kW	I_{hd} A	P_{hd} kW	dBA	W	m ³ /h		
$U_N = 400\text{ V}$ (Range 380 to 415 V). The power ratings are valid at nominal voltage 400 V.											
5.1	6.5	1.5	4.7	1.5	3.4	1.1	62	100	35	ACS800-04-0003-3	R2
6.5	8.2	2.2	5.9	2.2	4.3	1.5	62	120	35	ACS800-04-0004-3	R2
8.5	10.8	3	7.7	3	5.7	2.2	62	140	35	ACS800-04-0005-3	R2
10.9	13.8	4	10.2	4	7.5	3	62	160	35	ACS800-04-0006-3	R2
13.9	17.6	5.5	12.7	5.5	9.3	4	62	200	35	ACS800-04-0009-3	R2
19	24	7.5	18	7.5	14	5.5	62	250	69	ACS800-04-0011-3	R3
25	32	11	24	11	19	7.5	62	340	69	ACS800-04-0016-3	R3
34	46	15	31	15	23	11	62	440	69	ACS800-04-0020-3	R3
40	46	22	39	18.5	28	15	62	520	69	ACS800-04-0023-3	R3
44	62	22	41	18.5	32	15	62	530	103	ACS800-04-0025-3	R4
55	72	30	50	22	37	18.5	62	610	103	ACS800-04-0030-3	R4
59	72	30	57	30	41	22	62	660	103	ACS800-04-0035-3	R4
72	86	37	69	30	49	22	65	810	250	ACS800-04-0040-3	R5
86	112	45	80	37	60	30	65	990	250	ACS800-04-0050-3	R5
103	138	55	100	55	69	37	65	1190	250	ACS800-04-0060-3	R5
145	170	75	141	75	100	45	65	1440	250	ACS800-04-0075-3	R5
166	202	90	155	75	115	55	65	1940	405	ACS800-04-0100-3	R6
202	282	110	184	90	141	75	65	2310	405	ACS800-04-0120-3	R6
225	326	110	220	110	163	90	65	2810	405	ACS800-04-0135-3	R6
260	326	132	254	132	215	110	65	3260	405	ACS800-04-0165-3	R6
290	351	160	285	160	234	132	65	4200	405	ACS800-04-0205-3	R6
206	326	110	202	110	163	90	71	3000	540	ACS800-04(M)-0140-3	R7
248	404	132	243	132	202	110	71	3650	540	ACS800-04(M)-0170-3	R7
289	432	160	284	160	240 ¹⁾	132	71	4300	540	ACS800-04(M)-0210-3	R7
445	588	200	440	200	340	160	72	6600	1220	ACS800-04(M)-0260-3	R8
521	588	250	516	250	370	200	72	7150	1220	ACS800-04(M)-0320-3	R8
602	840	315	590	315	477	250	72	8100	1220	ACS800-04(M)-0400-3	R8
693	1017	355	679	355	590 ²⁾	315	72	8650	1220	ACS800-04(M)-0440-3	R8
720	1017	400	704	400	635 ³⁾	355	72	9100	1220	ACS800-04(M)-0490-3	R8
879	1315	500	844	500	657	400	73	13000	3120	ACS800-04-0610-3	1xD4 + 2xR8i
1111	1521	630	1067	630	831	450	74	17200	3840	ACS800-04-0770-3	2xD4 + 2xR8i
1255	1877	710	1205	710	939	500	74	18500	3840	ACS800-04-0870-3	2xD4 + 2xR8i
1452	1988	800	1394	800	1086	630	74	23900	3840	ACS800-04-1030-3	2xD4 + 2xR8i
1770	2648	1000	1699	1000	1324	710	75	27500	5040	ACS800-04-1230-3	2xD4 + 3xR8i
2156	2951	1200	2070	1200	1613	900	76	35400	5760	ACS800-04-1540-3	3xD4 + 3xR8i
2663	3984	1450	2556	1450	1992	1120	76	42700	6960	ACS800-04-1850-3	3xD4 + 4xR8i

Enclosure

Degree of protection:

IP00 standard for 04 and 04(M) frame sizes R7, R8 and nxR8i

IP20 standard for -04 frame sizes R2 to R6, option for some 04(M) variants

Paint color: RAL 9002/PMS 420C

Dimensions

Frame size	Height mm	Width mm	Depth mm	Weight kg
R2	370	165	193 ⁶⁾	8
R3	420	173	232 ⁶⁾	13
R4	490	240	253 ⁶⁾	24
R5	602	265	276	32
R6	700	300	399	64
R7	1121/1152/1126 ⁷⁾	427/632/264 ⁷⁾	473/259/467 ⁷⁾	100
R8	1564/1596 ⁸⁾	562/779 ⁸⁾	568/403 ⁸⁾	205
D4	1480	234	400 ¹⁰⁾	180
2xD4	1480	234 ⁹⁾	400 ¹⁰⁾	360
3xD4	1480	234 ⁹⁾	400 ¹⁰⁾	540
2xR8i	1397	245 ⁹⁾	596	300
3xR8i	1397	245 ⁹⁾	596	450
4xR8i	1397	245 ⁹⁾	596	600

Nominal ratings	
$I_{\text{cont. max}}$	Rated current available continuously without overloadability at 40 °C.
I_{max}	Maximum output current. Available for 10 s at start, otherwise as long as allowed by drive temperature. Note: max. motor shaft power is 150% P_{hd} .
Typical ratings: No-overload use	
$P_{\text{cont. max}}$	Typical motor power in no-overload use.
Light-overload use	
I_N	Continuous current allowing 110% I_N for 1 min / 5 min at 40 °C.
P_N	Typical motor power in light-overload use.
Heavy-duty use	
I_{hd}	Continuous current allowing 150% I_{hd} for 1 min / 5 min at 40 °C.
P_{hd}	Typical motor power in heavy-duty use.

The current ratings are the same regardless of the supply voltage within one voltage range.

The ratings apply at 40 °C ambient temperature. At higher temperatures (up to 50 °C) the derating is 1% / 1 °C.

Notes:

- 50% overload available if $T_{\text{amb}} < 25\text{ °C}$. If $T_{\text{amb}} = 40\text{ °C}$, max overload is 37%.
- 50% overload available if $T_{\text{amb}} < 30\text{ °C}$. If $T_{\text{amb}} = 40\text{ °C}$, max overload is 40%.
- 50% overload available if $T_{\text{amb}} < 20\text{ °C}$. If $T_{\text{amb}} = 40\text{ °C}$, max overload is 30%.
- 50% overload available if $T_{\text{amb}} < 35\text{ °C}$. If $T_{\text{amb}} = 40\text{ °C}$, max overload is 45%.
- Higher value available if output frequency is above 41 Hz.
- Please note that use of control panel or I/O extension or communication options increases the depth.
- Bookshelf (in ACS800-04M +H354) / flat (+H360) / bottom exit (+H352) version.
- Bookshelf (in ACS800-04M +H354) / flat (+H360) mounting.
- Single module only.
- Cable connections need additional space (about 200 mm) behind the module.

Ratings, types and voltages

ACS800-04, single drive modules, $U_N = 500\text{ V}$

ACS800 - 04 - XXXX - 5 + XXXX

Nominal ratings		No-overload use	Light-overload use		Heavy-duty use		Noise level dBA	Heat dissipation W	Air flow m ³ /h	Type designation	Frame size
$I_{\text{cont. max}}$ A	I_{max} A	$P_{\text{cont. max}}$ kW	I_N A	P_N kW	I_{hd} A	P_{hd} kW					
$U_N = 500\text{ V}$ (Range 380 to 500 V). The power ratings are valid at nominal voltage 500 V.											
4.9	6.5	2.2	4.5	2.2	3.4	1.5	62	120	35	ACS800-04-0004-5	R2
6.2	8.2	3	5.6	3	4.2	2.2	62	140	35	ACS800-04-0005-5	R2
8.1	10.8	4	7.7	4	5.6	3	62	160	35	ACS800-04-0006-5	R2
10.5	13.8	5.5	10	5.5	7.5	4	62	200	35	ACS800-04-0009-5	R2
13.2	17.6	7.5	12	7.5	9.2	5.5	62	250	35	ACS800-04-0011-5	R2
19	24	11	18	11	13	7.5	62	340	69	ACS800-04-0016-5	R3
25	32	15	23	15	18	11	62	440	69	ACS800-04-0020-5	R3
34	46	18.5	31	18.5	23	15	62	530	69	ACS800-04-0025-5	R3
38	46	22	37	22.0	27	19	62	590	69	ACS800-04-0028-5	R3
42	62	22	39	22	32	18.5	62	610	103	ACS800-04-0030-5	R4
48	72	30	44	30	36	22	62	810	103	ACS800-04-0040-5	R4
56	72	37	54	37	39	22	62	950	103	ACS800-04-0045-5	R4
65	86	37	61	37	50	30	65	990	250	ACS800-04-0050-5	R5
79	112	45	75	45	60	37	65	1190	250	ACS800-04-0060-5	R5
96	138	55	88	55	69	45	65	1440	250	ACS800-04-0070-5	R5
145	170	90	141	90	100	55	65	2150	250	ACS800-04-0105-5	R5
157	202	90	145	90	113	75	65	2310	405	ACS800-04-0120-5	R6
180	282	110	163	110	141	90	65	2810	405	ACS800-04-0140-5	R6
225	326	132	220	132	163	110	65	3260	405	ACS800-04-0165-5	R6
260	326	160	254	160	215	132	65	3800	405	ACS800-04-0205-5	R6
290	351	200	285	200	234	160	65	4500	405	ACS800-04-0255-5	R6
196	326	132	192	132	162	110	71	3000	540	ACS800-04(M)-0170-5	R7
245	384	160	240	160	192	132	71	3800	540	ACS800-04(M)-0210-5	R7
289	432	200	284	200	224	160	71	4500	540	ACS800-04(M)-0260-5	R7
440	588	250	435	250	340	200	72	6850	1220	ACS800-04(M)-0320-5	R8
515	588	315	510	315	370	250	72	7800	1220	ACS800-04(M)-0400-5	R8
550	840	355	545	355	490	315	72	7600	1220	ACS800-04(M)-0440-5	R8
602	840	400	590	400	515 ²⁾	355	72	8100	1220	ACS800-04(M)-0490-5	R8
684	1017	450	670	450	590 ²⁾	400	72	9100	1220	ACS800-04(M)-0550-5	R8
718	1017	500	704	500	632 ³⁾	450	72	9700	1220	ACS800-04(M)-0610-5	R8
883	1321	630	848	630	660	500	73	14000	3120	ACS800-04-0760-5	1xD4 + 2xR8i
1050	1524	710	1008	710	785	560	74	17200	3840	ACS800-04-0910-5	2xD4 + 2xR8i
1258	1882	900	1208	900	941	630	74	19900	3840	ACS800-04-1090-5	2xD4 + 2xR8i
1372	1991	1000	1317	1000	1026	710	74	23800	3840	ACS800-04-1210-5	2xD4 + 2xR8i
1775	2655	1250	1704	1200	1328	900	75	29400	5040	ACS800-04-1540-5	2xD4 + 3xR8i
2037	2956	1450	1956	1400	1524	1120	76	35000	5760	ACS800-04-1820-5	3xD4 + 3xR8i
2670	3901	1900	2563	1850	1997	1400	76	45400	6960	ACS800-04-2310-5	3xD4 + 4xR8i

Enclosure

Degree of protection:

IP00 standard for 04 and 04(M) frame sizes R7, R8 and nxR8i

IP20 standard for -04 frame sizes R2 to R6, option for some 04(M) variants

Paint color: RAL 9002/PMS 420C

Dimensions

Frame size	Height mm	Width mm	Depth mm	Weight kg
R2	370	165	193 ⁶⁾	8
R3	420	173	232 ⁶⁾	13
R4	490	240	253 ⁶⁾	24
R5	602	265	276	32
R6	700	300	399	64
R7	1121/1152/1126 ⁷⁾	427/632/264 ⁷⁾	473/259/467 ⁷⁾	100
R8	1564/1596 ⁸⁾	562/779 ⁸⁾	568/403 ⁸⁾	205
D4	1480	234	400 ¹⁰⁾	180
2xD4	1480	234 ⁹⁾	400 ¹⁰⁾	360
3xD4	1480	234 ⁹⁾	400 ¹⁰⁾	540
2xR8i	1397	245 ⁹⁾	596	300
3xR8i	1397	245 ⁹⁾	596	450
4xR8i	1397	245 ⁹⁾	596	600

Nominal ratings

$I_{\text{cont. max}}$: Rated current available continuously without overloadability at 40 °C.

I_{max} : Maximum output current. Available for 10 s at start, otherwise as long as allowed by drive temperature. Note: max. motor shaft power is 150% P_{hd} .

Typical ratings: No-overload use

$P_{\text{cont. max}}$: Typical motor power in no-overload use.

Light-overload use

I_N : Continuous current allowing 110% I_N for 1 min / 5 min at 40 °C.

P_N : Typical motor power in light-overload use.

Heavy-duty use

I_{hd} : Continuous current allowing 150% I_{hd} for 1 min / 5 min at 40 °C.

P_{hd} : Typical motor power in heavy-duty use.

The current ratings are the same regardless of the supply voltage within one voltage range.

The ratings apply at 40 °C ambient temperature. At higher temperatures (up to 50 °C) the derating is 1% / 1 °C.

Notes:

1) 50% overload available if $T_{\text{amb}} < 25\text{ °C}$. If $T_{\text{amb}} = 40\text{ °C}$, max overload is 37%.

2) 50% overload available if $T_{\text{amb}} < 30\text{ °C}$. If $T_{\text{amb}} = 40\text{ °C}$, max overload is 40%.

3) 50% overload available if $T_{\text{amb}} < 20\text{ °C}$. If $T_{\text{amb}} = 40\text{ °C}$, max overload is 30%.

4) 50% overload available if $T_{\text{amb}} < 35\text{ °C}$. If $T_{\text{amb}} = 40\text{ °C}$, max overload is 45%.

5) Higher value available if output frequency is above 41 Hz.

6) Please note that use of control panel or I/O extension or communication options increases the depth.

7) Bookshelf (in ACS800-04M +H354) / flat (+H360) / bottom exit (+H352) version.

8) Bookshelf (in ACS800-04M +H354) / flat (+H360) mounting.

9) Single module only.

10) Cable connections need additional space (about 200 mm) behind the module.

Ratings, types and voltages

ACS800-04, single drive modules, $U_N = 690$ V

ACS800 - 04 - XXXX - 7 + XXXX

Nominal ratings		No-overload use	Light-overload use	Heavy-duty use		Noise level	Heat dissipation	Air flow	Type designation	Frame size	
$I_{cont.max}$ A	I_{max} A	$P_{cont.max}$ kW	I_N A	P_N kW	I_{hd} A	P_{hd} kW	dBA	W	m ³ /h		
$U_N = 690$ V (Range 525 to 690 V). The power ratings are valid at nominal voltage 690 V.											
13	14	11	11.5	7.5	8.5	5.5	62	300	103	ACS800-04-0011-7	R4
17	19	15	15	11	11	7.5	62	340	103	ACS800-04-0016-7	R4
22	28	18.5	20	15	15	11	62	440	103	ACS800-04-0020-7	R4
25	38	22	23	18.5	19	15	62	530	103	ACS800-04-0025-7	R4
33	44	30	30	22	22	18.5	62	610	103	ACS800-04-0030-7	R4
36	54	30	34	30	27	22	62	690	103	ACS800-04-0040-7	R4
51	68	45	46	37	34	30	65	840	250	ACS800-04-0050-7	R5
57	84	55	52	45	42	37	65	1010	250	ACS800-04-0060-7	R5
79	104	75	73	55	54	45	65	1220	405	ACS800-04-0070-7	R6
93	124	90	86	75	62	55	65	1650	405	ACS800-04-0100-7	R6
113	172	110	108	90	86	75	65	1960	405	ACS800-04-0120-7	R6
134	190	132	125	110	95	90	65	2660	405	ACS800-04-0145-7	R6
166	245	160	155	132	131	110	65	3470	405	ACS800-04-0175-7	R6
190	245	160	180	160	147	132	65	4180	405	ACS800-04-0205-7	R6
134	190	132	125	110	95	90	71	2800	540	ACS800-04(M)-0140-7	R7
166	263	160	155	132	131	110	71	3550	540	ACS800-04(M)-0170-7	R7
166/203 ⁵⁾	294	160	165/195 ⁵⁾	160	147	132	71	4250	540	ACS800-04(M)-0210-7	R7
175/230 ⁵⁾	326	160/200 ⁵⁾	175/212 ⁵⁾	160/200 ⁵⁾	163	160	71	4800	540	ACS800-04(M)-0260-7	R7
315	433	315	290	250	216	200	72	6150	1220	ACS800-04(M)-0320-7	R8
353	548	355	344	315	274	250	72	6650	1220	ACS800-04(M)-0400-7	R8
396	656	400	387	355	328	315	72	7400	1220	ACS800-04(M)-0440-7	R8
445	775	450	426	400	387	355	72	8450	1220	ACS800-04(M)-0490-7	R8
488	853	500	482	450	426	400	72	8300	1220	ACS800-04(M)-0550-7	R8
560	964	560	537	500	482	450	72	9750	1220	ACS800-04(M)-0610-7	R8
628	939	630	603	630	470	500	73	13900	3120	ACS800-04-0750-7	1xD4 + 2xR8i
729	1091	710	700	710	545	560	73	17100	3120	ACS800-04-0870-7	1xD4 + 2xR8i
885	1324	800	850	800	662	630	73	18400	3120	ACS800-04-1060-7	1xD4 + 2xR8i
953	1426	900	915	900	713	710	74	20800	3840	ACS800-04-1160-7	2xD4 + 2xR8i
1258	1882	1200	1208	1200	941	900	75	27000	5040	ACS800-04-1500-7	2xD4 + 3xR8i
1414	2115	1400	1357	1400	1058	1000	75	32500	5040	ACS800-04-1740-7	2xD4 + 3xR8i
1774	2654	1700	1703	1700	1327	1250	76	40100	6240	ACS800-04-2120-7	2xD4 + 4xR8i
1866	2792	1900	1791	1800	1396	1400	76	43300	6960	ACS800-04-2320-7	3xD4 + 4xR8i

Enclosure

Degree of protection:

IP00 standard for 04 and 04(M) frame sizes R7, R8 and nxR8i

IP20 standard for -04 frame sizes R2 to R6, option for some 04(M) variants

Paint color: RAL 9002/PMS 420C

Dimensions

Frame size	Height mm	Width mm	Depth mm	Weight kg
R2	370	165	193 ⁶⁾	8
R3	420	173	232 ⁶⁾	13
R4	490	240	253 ⁶⁾	24
R5	602	265	276	32
R6	700	300	399	64
R7	1121/1152/1126 ⁷⁾	427/632/264 ⁷⁾	473/259/467 ⁷⁾	100
R8	1564/1596 ⁸⁾	562/779 ⁸⁾	568/403 ⁸⁾	205
D4	1480	234	400 ¹⁰⁾	180
2xD4	1480	234 ⁹⁾	400 ¹⁰⁾	360
3xD4	1480	234 ⁹⁾	400 ¹⁰⁾	540
2xR8i	1397	245 ⁹⁾	596	300
3xR8i	1397	245 ⁹⁾	596	450
4xR8i	1397	245 ⁹⁾	596	600

Nominal ratings

$I_{cont.max}$	Rated current available continuously without overloadability at 40 °C.
I_{max}	Maximum output current. Available for 10 s at start, otherwise as long as allowed by drive temperature. Note: max. motor shaft power is 150% P_{hd} .

Typical ratings: No-overload use

$P_{cont.max}$	Typical motor power in no-overload use.
----------------	---

Light-overload use

I_N	Continuous current allowing 110% I_N for 1 min / 5 min at 40 °C.
P_N	Typical motor power in light-overload use.

Heavy-duty use

I_{hd}	Continuous current allowing 150% I_{hd} for 1 min / 5 min at 40 °C.
P_{hd}	Typical motor power in heavy-duty use.

The current ratings are the same regardless of the supply voltage within one voltage range.

The ratings apply at 40 °C ambient temperature. At higher temperatures (up to 50 °C) the derating is 1% / 1 °C.

Notes:

- 50% overload available if $T_{amb} < 25$ °C. If $T_{amb} = 40$ °C, max overload is 37%.
- 50% overload available if $T_{amb} < 30$ °C. If $T_{amb} = 40$ °C, max overload is 40%.
- 50% overload available if $T_{amb} < 20$ °C. If $T_{amb} = 40$ °C, max overload is 30%.
- 50% overload available if $T_{amb} < 35$ °C. If $T_{amb} = 40$ °C, max overload is 45%.
- Higher value available if output frequency is above 41 Hz.
- Please note that use of control panel or I/O extension or communication options increases the depth.
- Bookshelf (in ACS800-04M +H354) / flat (+H360) / bottom exit (+H352) version.
- Bookshelf (in ACS800-04M +H354) / flat (+H360) mounting.
- Single module only.
- Cable connections need additional space (about 200 mm) behind the module.

Ratings, types and voltages

ACS800-14, single drive modules, $U_N = 400$ to 690 V



Nominal ratings		No-overload use	Light-overload use		Heavy-duty use		Noise level	Heat dissipation	Air flow	Type designation	Frame size
$I_{cont,max}$ A	$I_{cont,max}$ A	$P_{cont,max}$ kW	I_N A	P_N kW	I_{hd} A	P_{hd} kW	dBA	kW	m ³ /h		
$U_N = 400$ V (Range 380 to 415 V)											
202	293	110	194	90	151	75	74	6.3	1300	ACS800-14-0140-3	R7i + R7i + ALCL-04-5
250	363	132	240	132	187	90	74	6.9	1300	ACS800-14-0170-3	R7i + R7i + ALCL-05-5
292	400	160	280	160	218	110	75	7	3160	ACS800-14-0210-3	R8i + R8i + ALCL-12-5
370	506	200	244	200	277	132	75	9	3160	ACS800-14-0260-3	R8i + R8i + ALCL-13-5
469	642	250	450	250	351	200	75	11	3160	ACS800-14-0320-3	R8i + R8i + ALCL-14-5
565	773	315	542	315	423	250	75	14	3160	ACS800-14-0390-3	R8i + R8i + ALCL-15-5
704	963	400	675	355	526	250	75	19	3160	ACS800-14-0490-3	R8i + R8i + ALCL-15-5
919	1258	500	882	500	688	355	77	22	6400	ACS800-14-0640-3	2xR8i + 2xR8i + ALCL-24-5
1111	1521	630	1067	630	831	450	77	28	6400	ACS800-14-0770-3	2xR8i + 2xR8i + ALCL-25-5
1379	1888	800	1324	710	1037	560	77	36	6400	ACS800-14-0960-3	2xR8i + 2xR8i + ALCL-25-5
1535	2102	900	1474	800	1149	630	78	39	10240	ACS800-14-1070-3	3xR8i + 3xR8i + 2xALCL-24-5
1978	2707	1200	1899	1100	1479	800	78	51	10240	ACS800-14-1380-3	3xR8i + 3xR8i + 2xALCL-24-5
2610	3573	1600	2506	1400	1953	1100	79	67	12800	ACS800-14-1810-3	4xR8i + 4xR8i + 2xALCL-24-5
$U_N = 500$ V (Range 380 to 500 V)											
200	291	132	192	132	150	90	74	6	1300	ACS800-14-0170-5	R7i + R7i + ALCL-04-5
245	356	160	235	160	183	110	74	8	1300	ACS800-14-0210-5	R7i + R7i + ALCL-05-5
302	347	200	289	200	226	132	75	8	3160	ACS800-14-0260-5	R8i + R8i + ALCL-12-5
365	457	250	350	250	273	160	75	10	3160	ACS800-14-0320-5	R8i + R8i + ALCL-13-5
455	530	315	437	315	340	200	75	12	3160	ACS800-14-0400-5	R8i + R8i + ALCL-14-5
525	660	355	504	355	393	250	75	14	3160	ACS800-14-0460-5	R8i + R8i + ALCL-15-5
595	648	400	571	400	445	315	75	16	3160	ACS800-14-0510-5	R8i + R8i + ALCL-15-5
670	972	500	643	450	501	315	75	19	3160	ACS800-14-0580-5	R8i + R8i + ALCL-15-5
892	1294	630	856	630	667	450	77	24	6400	ACS800-14-0780-5	2xR8i + 2xR8i + ALCL-24-5
1005	1458	710	956	630	752	500	77	28	6400	ACS800-14-0870-5	2xR8i + 2xR8i + ALCL-25-5
1313	1906	900	1261	900	982	710	77	36	6400	ACS800-14-1140-5	2xR8i + 2xR8i + ALCL-25-5
1528	2217	1120	1467	1120	1143	800	78	41	10240	ACS800-14-1330-5	3xR8i + 3xR8i + 2xALCL-24-5
1884	2734	1400	1809	1300	1409	1000	78	52	10240	ACS800-14-1640-5	3xR8i + 3xR8i + 2xALCL-24-5
2486	3608	1800	2387	1700	1860	1300	79	68	12800	ACS800-14-2160-5	4xR8i + 4xR8i + 2xALCL-25-5
$U_N = 690$ V (Range 525 to 690 V)											
132	192	110	127	110	99	90	74	7	1300	ACS800-14-0160-7	R7i + R7i + ALCL-04-7
150	218	132	144	132	112	90	74	8	1300	ACS800-14-0200-7	R7i + R7i + ALCL-05-7
201	238	200	193	160	150	132	75	11	3160	ACS800-14-0260-7	R8i + R8i + ALCL-12-7
279	311	250	268	250	209	200	75	12	3160	ACS800-14-0320-7	R8i + R8i + ALCL-13-7
335	431	315	322	250	251	200	75	16	3160	ACS800-14-0400-7	R8i + R8i + ALCL-14-7
382	503	355	367	355	286	270	75	17	3160	ACS800-14-0440-7	R8i + R8i + ALCL-15-7
447	525	450	429	400	334	315	75	18	3160	ACS800-14-0540-7	R8i + R8i + ALCL-15-7
659	727	630	632	630	493	450	77	32	6400	ACS800-14-0790-7	2xR8i + 2xR8i + ALCL-24-7
729	985	710	700	710	545	500	77	33	6400	ACS800-14-0870-7	2xR8i + 2xR8i + ALCL-25-7
896	1002	900	840	800	655	350	77	36	6400	ACS800-14-1050-7	2xR8i + 2xR8i + ALCL-25-7
1112	1425	1120	1037	1120	831	800	78	48	10240	ACS800-14-1330-7	3xR8i + 3xR8i + 2xALCL-24-7
1256	1477	1250	1206	1200	940	900	78	51	10240	ACS800-14-1510-7	3xR8i + 3xR8i + 2xALCL-24-7
1657	1879	1700	1591	1600	1240	1200	79	67	12800	ACS800-14-1980-7	4xR8i + 4xR8i + 2xALCL-25-7

Dimensions

Frame size	Height mm	Width mm	Depth ¹⁾ mm	Weight kg
R7i ¹⁾	963	170	408	38
R8i	1397	245 ²⁾	596	130
2xR8i	1397	245 ²⁾	596	260
3xR8i	1397	245 ²⁾	596	390
4xR8i	1397	245 ²⁾	596	520

¹⁾ Dimensions do not include cooling fan

²⁾ Single module only

Frame size	Height mm	Width mm	Depth mm	Weight kg
ALCL-0x-x	810	304	292	72
ALCL-1x-x	1397	240	499	180
ALCL-2x-x	1397	240	573	305

Nominal ratings	
$I_{cont,max}$	Rated current available continuously without overloadability at 40 °C.
I_{max}	Maximum output current. Available for 10 s at start, otherwise as long as allowed by drive temperature. Note: max. motor shaft power is 150% P_{hd} .
Typical ratings: No-overload use	
$P_{cont,max}$	Typical motor power in no-overload use.
Light-overload use	
I_N	Continuous current allowing 110% I_N for 1 min / 5 min at 40 °C.
P_N	Typical motor power in light-overload use.
Heavy-duty use	
I_{hd}	Continuous current allowing 150% I_{hd} for 1 min / 5 min at 40 °C.
P_{hd}	Typical motor power in heavy-duty use.

The current ratings are the same regardless of the supply voltage within one voltage range.

The ratings apply at 40 °C ambient temperature. At higher temperatures (up to 50 °C) the derating is 1% / 1 °C.

Multidrive modules

ACS800-X04

The ACS800 multidrive module product range includes rectifier- and DC-supplied inverter modules and accessories especially designed for integrators, machine builders and panel builders.

The ACS800 multidrive principle based on a common DC bus arrangement enables single power entry and common braking resources for several drives. Common braking includes the possibility for regenerative braking and motor-to-motor braking depending on the motor loads in the line-up.

Special design for system integrators

The design of these modules is based on much smaller inverter modules.

The modules have a plug-in connector, meaning fast and easy assembling. The modules are also equipped with wheels, so they can easily be pulled out of the cabinet and pushed back for maintenance purposes.

This concept also allows pre-installation of the power cables in the empty cabinet.

Inverter and diode modules can be freely connected parallel for higher output current. This means a limited number of different module sizes and fewer spare parts.

The modularity, compact size and simplicity of the modules means a lot of savings for cabinet builders in terms of minimizing the number of cabinets and the widths.

Besides the compact design, the new ACS800 DC-supplied inverter and rectifier units include an extensive selection of options.

Product range

Inverter modules

Inverter modules are available in 7 different frame sizes. Frame sizes R2i to R7i start from 1.1 to 110 kW, and all the powers from 90 to 2000 kW are different configurations of R8i units, single or in parallel. The voltage range covers 380 V, 500 V and 690 V.

Supply modules

Supply modules are available as diode-, thyristor- or IGBT-based solutions.

In the diode supply units (DSU) only four different types of unit, either in single or parallel, cover the power range of 145 to 4200 kW in 380 to 690 V.

The basic features of the diode rectifier unit include automatic adaptation to 6 or 12-pulse operation and automatic control to charge the inverter capacitor banks during start-up.

The mechanical dimensions are the same in each module, making engineering and assembling very easy.

The thyristor supply unit (TSU) is used in regenerative drive systems. It contains two 6-pulse thyristor bridges in antiparallel connections. 12-pulse units can also be configured. The power range is from 470 to 3150 kW in 380 to 690 V.

An IGBT Supply unit (ISU) is used in fully regenerative drive systems. In power control it gives the same firm and gentle performance as DTC gives in motor control. The power module is hardware compatible with the inverter module. In passive mode the converter operates as the rectifier. In the active mode the IGBTs are controlled to keep the DC voltage constant and the line current sinusoidal.

Harmonic content remains extremely low due to DTC control and LCL filtering.

The power range is from 2.7 to 2900 kW in 380 to 690 V. Modules are single or parallel connected.

Braking choppers and resistors

In resistor braking whenever the voltage in the intermediate circuit of a frequency converter exceeds a certain limit, a braking chopper connects the circuit to a braking resistor.

Standard resistors are also available, but non-standard resistors can be used, however they must be checked case-by-case.

The power range is from 230 to 2400 kW in 380 to 690 V.

Multidrive modules

ACS800-X04

Main standard hardware features

- Frame sizes R2i to R5i control board inside of the module
- Frame sizes R7i to n*R8i control board outside of the module
- Extensive, programmable I/O
- Three I/O and fieldbus extension slots
- Inputs galvanically isolated
- Optimised design for cabinet assembly
- Modular design allowing wide variety of variants
- Compact design
- Long lifetime cooling fan and capacitors
- du/dt filters as standard in parallel connected R8i and in single or parallel connected 690 V inverter units
- Mounting on the cabinet wall frame size R2i to R7i and on the cabinet floor for R8i and the D3/D4 supply module
- Wheels and plug connectors in the R8i inverter and D3/D4 supply module
- Coated boards
- LCL-filter units in ISUs

Main optional hardware features

Inverter frame sizes R2i to R7i:

- Prevention of unexpected start-up
- DC fuses, fuse bases or DC-fuse switch
- Mechanics for tilted position assembly in R2i to R5i frame size
- Assembly plates for R7i units
- du/dt filters
- Common mode filter for motor protection
- On-off control for cooling fan with internal charging option
- Mechanical accessories in Rittal TS8 cabinets (only for R7)
 - IP21 to IP54 cabinet door / roof mechanical kits
 - Accessories kits
- Safe torque-off

Inverter frame sizes R8i to n*R8i:

- Prevention of unexpected start-up
- DC fuses, fuse bases or DC-fuse switch + charging circuitry
- du/dt filters as options in 400 / 500 V
- Mechanical accessories in Rittal TS8 cabinets
 - IP21 to IP54 cabinet door / roof mechanical kits
 - Accessories kits
- Common mode filters for motor protection
- Safe torque-off (STO)

DSU frame sizes D3 to n*D4:

- Contactor (inside the module)
- RFI filter up to 1000 A
- Front end AC-fuses
- Air circuit breaker
- Mechanical accessories in Rittal TS8 cabinets
 - IP21 to IP54 cabinet door / roof mechanical kits
 - Accessories kits



Ratings, types and voltages

ACS800-X04, drive module, $U_N = 400\text{ V}$

ACS800 - X04 - XXXX - 3 + XXXX

Nominal ratings		No-overload use	Light-overload use		Heavy-duty use		Heat dissipation kW	Type designation	Frame size
$I_{\text{cont. max}}$ A	I_{max} A	$P_{\text{cont. max}}$ kW	I_N A	P_N kW	I_{hd} A	P_{hd} kW			
$U_N = 400\text{ V}$ (Range 380 to 415 V). The power ratings are valid at nominal voltage 400 V.									
5.1	6.5	1.5	4.7	1.5	3.4	1.1	0.1	ACS800-104-0003-3	R2i
6.5	8.2	2.2	5.9	2.2	4.3	1.5	0.1	ACS800-104-0004-3	R2i
8.5	10.8	3	7.7	3	5.7	2.2	0.1	ACS800-104-0005-3	R2i
10.9	13.8	4	10.2	4	7.5	3	0.1	ACS800-104-0006-3	R2i
13.9	17.6	5.5	12.7	5.5	9.3	4	0.2	ACS800-104-0009-3	R2i
19	24	7.5	18	7.5	14	5.5	0.3	ACS800-104-0011-3	R3i
25	32	11	24	11	19	7.5	0.3	ACS800-104-0016-3	R3i
34	46	15	31	15	23	11	0.4	ACS800-104-0020-3	R3i
44	62	22	41	18.5	32	15	0.5	ACS800-104-0025-3	R4i
55	72	30	50	22	37	18.5	0.6	ACS800-104-0030-3	R4i
72	86	37	69	30	49	22	0.8	ACS800-104-0040-3	R5i
86	112	45	80	37	60	30	1	ACS800-104-0050-3	R5i
103	138	55	94	45	69	37	1.2	ACS800-104-0060-3	R5i
147	220	75	141	75	110	55	1.4	ACS800-104-0105-3	R7i
178	252	90	171	90	133	55	1.7	ACS800-104-0125-3	R7i
208	312	110	200	110	156	75	1.9	ACS800-104-0145-3	R7i
250	374	132	240	132	187	90	2.1	ACS800-104-0175-3	R7i
292	400	160	280	160	218	110	2.7	ACS800-104-0210-3	R8i
370	506	200	355	200	277	132	3.7	ACS800-104-0260-3	R8i
469	642	250	450	250	351	200	4.9	ACS800-104-0320-3	R8i
565	773	315	542	315	423	220	6.1	ACS800-104-0390-3	R8i
741	1014	400	711	400	554	315	8	ACS800-104-0510-3	R8i
1111	1521	630	1067	630	831	450	12	ACS800-104-0770-3	2xR8i
1452	1988	800	1394	800	1086	630	15	ACS800-104-1030-3	2xR8i
2156	2951	1200	2070	1200	1613	900	23	ACS800-104-1540-3	3xR8i
2845	3894	1600	2731	1600	2128	1120	30	ACS800-104-2050-3	4xR8i
3537	4842	2000	3396	2000	2646	1400	37	ACS800-104-2570-3	5xR8i
4223	5780	2400	4054	2400	3159	1600	44	ACS800-104-3080-3	6xR8i

Dimensions

Frame size	Height mm	Width mm	Depth mm	Weight kg	Noise level dB(A)	Air flow m ³ /h
R2i	401	165	193 ³⁾	9	62	35
R3i	466	173	232 ³⁾	12	62	69
R4i	525	240	252 ³⁾	15	62	103
R5i	673	265	276 ³⁾	23	65	168
R7i ¹⁾	963	170	408	38	64	800
R8i	1397	245	596	130	72	1280
2xR8i	1397	245 ²⁾	596	260	74	2560
3xR8i	1397	245 ²⁾	596	390	76	3840
4xR8i	1397	245 ²⁾	596	520	76	5120
5xR8i	1397	245 ²⁾	596	650	77	6400
6xR8i	1397	245 ²⁾	596	780	78	7680

¹⁾ Dimensions do not include cooling fan.

²⁾ Single module only.

³⁾ The depth is without control panels and options.

Type	Height mm	Width mm	Depth mm
RDCU control unit *)	282	126	41

*) Delivered with R7i to nxR8i

Nominal ratings	
$I_{\text{cont. max}}$	Rated current available continuously without overloadability at 40 °C.
I_{max}	Maximum output current. Available for 10 s at start, otherwise as long as allowed by drive temperature.
Typical ratings: No-overload use	
$P_{\text{cont. max}}$	Typical motor power in no-overload use.
Light-overload use	
I_N	Continuous current allowing 110% I_N for 1 min / 5 min at 40 °C.
P_N	Typical motor power in light-overload use.
Heavy-duty use	
I_{hd}	Continuous current allowing 150% I_{hd} for 1 min / 5 min at 40 °C.
P_{hd}	Typical motor power in heavy-duty use.

The current ratings are the same regardless of the supply voltage within one voltage range.

The ratings apply in 40 °C ambient temperature. In lower temperatures the ratings are higher (except I_{max}).

The rated current of the ACS800 must be higher than or equal to the rated motor current to achieve the rated motor power given in the table.

Ratings, types and voltages

ACS800-X04, supply module, $U_N = 400\text{ V}$



Nominal ratings				No-overload use	Light-overload use		Heavy-duty use		Heat dissipation kW	Type designation	Frame size
$I_{cont. max}$ A (AC)	$I_{cont. max}$ A (DC)	I_{max} A (DC)	S_N kVA	$P_{cont. max}$ kW (DC)	I_N A (DC)	P_N kW (DC)	I_{hd} A (DC)	P_{hd} kW (DC)			

$U_N = 400\text{ V}$ (Range 380 to 415 V). The power ratings are valid at nominal voltage 400 V.

IGBT supply module (ISU)

5.3	6.4	9.3	3.8	3.8	6.2	3.7	4.7	2.7	0.3	ACS800-204-0003-3	R2i + RLCL-01-5
11.3	13.7	19.9	8.1	8.0	13.2	8.0	9.9	5.8	0.5	ACS800-204-0008-3	R2i + RLCL-02-5
27.7	33.6	48.7	20.0	19.8	32.3	20	24.3	14.3	0.8	ACS800-204-0021-3	R3i + RLCL-03-5
44.9	54.4	78.7	32.2	31.9	52.2	32	39.4	23.1	1.3	ACS800-204-0031-3	R4i + RLCL-11-5
84.0	101.9	147.4	60.3	59.7	97.8	60	73.7	43.3	2.2	ACS800-204-0061-3	R5i + RLCL-12-5
182	221	330	131	130	212	124	165	97	3.8	ACS800-204-0135-3	R7i + ALCL-04-5
224	272	406	161	159	261	153	203	119	4.2	ACS800-204-0155-3	R7i + ALCL-05-5
284	344	471	204	202	331	194	258	151	5.9	ACS800-204-0200-3	R8i + ALCL-12-5
378	458	627	272	269	440	258	343	201	8	ACS800-204-0260-3	R8i + ALCL-13-5
473	573	784	340	336	550	323	429	252	10.3	ACS800-204-0330-3	R8i + ALCL-14-5
630	764	1046	453	448	733	430	571	335	14.6	ACS800-204-0440-3	R8i + ALCL-15-5
945	1146	1568	679	672	1100	646	857	503	20.5	ACS800-204-0660-3	2xR8i + ALCL-24-5
1235	1497	2049	888	879	1437	844	1120	657	28.3	ACS800-204-0860-3	2xR8i + ALCL-25-5
1833	2223	3042	1318	1304	2134	1252	1662	976	41.7	ACS800-204-1270-3	3xR8i + 2xALCL-24-5
2419	2933	4015	1739	1722	2816	1653	2194	1288	54.8	ACS800-204-1680-3	4xR8i + 2xALCL-25-5
3591	4354	5960	2581	2555	4180	2453	3257	1911	81	ACS800-204-2490-3	6xR8i + 3xALCL-25-5

6-pulse diode supply unit (DSU)

286	350	462	198	183	335	175	280	147	1.5	ACS800-304-0320-7	D3
408	500	700	283	262	480	251	400	210	2.4	ACS800-304-0450-7	D3
571	700	924	396	367	670	351	560	293	3.8	ACS800-704-0640-7	D4
816	1000	1400	566	524	960	503	800	419	5	ACS800-704-0910-7	D4
1143	1400	1848	792	733	1340	702	1120	587	7.6	ACS800-704-1370-7	2xD4
1518	1860	2604	1052	974	1790	938	1490	780	10	ACS800-704-1810-7	2xD4
2278	2790	3906	1578	1461	2685	1406	2230	1168	15	ACS800-704-2720-7	3xD4
3037	3720	5208	2104	1949	3580	1875	2980	1561	20	ACS800-704-3630-7	4xD4
3796	4650	6510	2630	2436	4475	2344	3720	1949	25	ACS800-704-4540-7	5xD4

6-pulse regenerative thyristor supply unit (TSU)

981	1202	1947	680	639	1136	604	880	468	6.3	ACS800-404-0680-3	2xB4 + choke
1617	1980	3208	1120	1053	1872	995	1450	721	10.2	ACS800-404-1120-3	2xB4 + choke
2449	3000	4860	1697	1595	2838	1509	2244	1193	16.5	ACS800-404-1700-3	2xB5 + choke
2858	3500	5670	1980	1861	3311	1760	2618	1392	20.8	ACS800-404-2100-3	2xB5 + choke

12-pulse diode supply unit (DSU)

571	700	924	396	367	670	351	560	293	3.8	ACS800-704-0640-7	D4
816	1000	1400	566	524	960	503	800	419	5	ACS800-704-0910-7	D4
1143	1400	1848	792	733	1340	702	1120	587	7.6	ACS800-704-1370-7	2xD4
1518	1860	2604	1052	974	1790	938	1490	780	10	ACS800-704-1810-7	2xD4
2278	2790	3906	1578	1461	2685	1406	2230	1168	15	ACS800-704-2720-7	3xD4
3037	3720	5208	2104	1949	3580	1875	2980	1561	20	ACS800-704-3630-7	4xD4
3796	4650	6510	2630	2436	4475	2344	3720	1949	25	ACS800-704-4540-7	5xD4

Dimensions

Frame size	Height mm	Width mm	Depth mm	Weight kg	Noise level dB(A)	Air flow m³/h
------------	--------------	-------------	-------------	--------------	----------------------	------------------

IGBT supply unit (ISU)

R2i	401	165	193	9	62	35
R3i	466	173	232	12	62	69
R4i	525	240	252	15	62	103
R5i	673	265	276	23	65	250
R7i ¹⁾	963	170	408	38	72 ⁴⁾	800
R8i	1397	245	596	130	74 ⁴⁾	1280
2xR8i	1397	245 ²⁾	596	260	76 ⁴⁾	2560
3xR8i	1397	245 ²⁾	596	390	78 ⁴⁾	3840
4xR8i	1397	245 ²⁾	596	520	78 ⁴⁾	5120
6xR8i	1397	245 ²⁾	596	780	80 ⁴⁾	7680

LCL-filter for IGBT supply unit (ISU)

RLCL-01-5	850	173	137	15	69	-
RLCL-02-5	850	173	137	15	69	-
RLCL-03-5	850	173	137	20	69	-
RLCL-11-5	920	265	169.5	40	69	-
RLCL-12-5	920	265	169.5	50	69	-
ALCL-0X-X	810	304	292	72	-	480
ALCL-1X-X	1397	240	499	180	-	400
ALCL-2X-X	1397	240	573	305	-	1280

Frame size	Height mm	Width mm	Depth mm	Weight kg	Noise level dB(A)	Air flow m³/h
------------	--------------	-------------	-------------	--------------	----------------------	------------------

6-pulse diode supply unit (DSU)

D3	1480	234	400 ³⁾	130	65	720
D4	1480	234	400 ³⁾	180	65	720
2XD4	1480	234 ²⁾	400 ³⁾	360	67	1440
3XD4	1480	234 ²⁾	400 ³⁾	540	68	2160
4XD4	1480	234 ²⁾	400 ³⁾	720	69	2880
5XD4	1480	234 ²⁾	400 ³⁾	900	70	3600

6-pulse regenerative thyristor supply unit (TSU)

2xB4	1808	340 ²⁾	430	110 ²⁾	72 ⁵⁾	2000
2xB5	1808	420 ²⁾	430	150 ²⁾	75 ⁵⁾	3400

DC chokes for 6-pulse regenerative supply unit (TSU)

choke B4	771	348	449	110	-	600
choke B5	991	348	449	150	-	700

12-pulse diode supply unit (DSU)

D4	1480	234	400 ³⁾	180	65	720
2XD4	1480	234 ²⁾	400 ³⁾	360	67	1440
3XD4	1480	234 ²⁾	400 ³⁾	540	68	2160
4XD4	1480	234 ²⁾	400 ³⁾	720	69	2880
5XD4	1480	234 ²⁾	400 ³⁾	900	70	3600

¹⁾ Dimensions do not include cooling fan.

²⁾ Single module only.

³⁾ Cable connections need additional space (about 200 mm) behind the module.

⁴⁾ Supply modules + filters.

⁵⁾ Supply modules + choke.

Ratings, types and voltages

ACS800-X04, drive module, $U_N = 500\text{ V}$

ACS800 - X04 - XXXX - 5 + XXXX

Nominal ratings		No-overload use	Light-overload use		Heavy-duty use		Heat dissipation kW	Type designation	Frame size
$I_{\text{cont. max}}$ A	I_{max} A	$P_{\text{cont. max}}$ kW	I_N A	P_N kW	I_{hd} A	P_{hd} kW			
$U_N = 500\text{ V}$ (Range 380 to 500 V). The power ratings are valid at nominal voltage 500 V.									
4.9	7	2.2	4.5	2.2	3.4	1.5	0.1	ACS800-104-0004-5	R2i
6.2	8	3	5.6	3	4.2	2.2	0.1	ACS800-104-0005-5	R2i
8.1	11	4	7.7	4	5.6	3	0.2	ACS800-104-0006-5	R2i
11	14	5.5	10	5.5	7.5	4	0.2	ACS800-104-0009-5	R2i
13	18	7.5	12	7.5	9.2	5.5	0.3	ACS800-104-0011-5	R2i
19	24	11	18	11	13	7.5	0.3	ACS800-104-0016-5	R3i
25	32	15	23	15	18	11	0.4	ACS800-104-0020-5	R3i
34	46	18.5	31	18.5	23	15	0.5	ACS800-104-0025-5	R3i
42	62	22	39	22	32	18.5	0.6	ACS800-104-0030-5	R4i
48	72	30	44	30	36	22	0.8	ACS800-104-0040-5	R4i
65	86	37	61	37	50	30	1	ACS800-104-0050-5	R5i
79	112	45	75	45	60	37	1.2	ACS800-104-0060-5	R5i
96	138	55	88	55	69	45	1.4	ACS800-104-0070-5	R5i
115	172	75	110	55	86	55	1.1	ACS800-104-0105-5	R7i
135	202	90	130	90	101	55	1.3	ACS800-104-0125-5	R7i
166	248	110	159	110	124	75	1.7	ACS800-104-0145-5	R7i
208	312	132	200	132	156	90	2	ACS800-104-0175-5	R7i
250	374	160	240	160	187	110	2.2	ACS800-104-0215-5	R7i
315	457	200	302	200	236	132	3.2	ACS800-104-0260-5	R8i
365	530	250	350	250	273	160	4	ACS800-104-0320-5	R8i
455	660	315	437	315	340	200	5.4	ACS800-104-0400-5	R8i
525	762	355	504	355	393	250	5.9	ACS800-104-0460-5	R8i
700	1016	500	672	500	524	355	7.8	ACS800-104-0610-5	R8i
1050	1524	710	1008	710	785	560	12	ACS800-104-0910-5	2xR8i
1372	1991	1000	1317	1000	1026	710	15	ACS800-104-1210-5	2xR8i
2037	2956	1450	1956	1450	1524	1120	22	ACS800-104-1820-5	3xR8i
2688	3901	2000	2580	1850	2011	1400	29	ACS800-104-2430-5	4xR8i
3343	4850	2400	3209	2400	2500	1600	36	ACS800-104-3030-5	5xR8i
3990	5790	2900	3830	2900	2985	2000	43	ACS800-104-3640-5	6xR8i

Dimensions

Frame size	Height mm	Width mm	Depth mm	Weight kg	Noise level dB(A)	Air flow m ³ /h
R2i	401	165	193 ³⁾	9	62	35
R3i	466	173	232 ³⁾	12	62	69
R4i	525	240	252 ³⁾	15	62	103
R5i	673	265	276 ³⁾	23	65	168
R7i ¹⁾	963	170	408	38	64	800
R8i	1397	245	596	130	72	1280
2xR8i	1397	245 ²⁾	596	260	74	2560
3xR8i	1397	245 ²⁾	596	390	76	3840
4xR8i	1397	245 ²⁾	596	520	76	5120
5xR8i	1397	245 ²⁾	596	650	77	6400
6xR8i	1397	245 ²⁾	596	780	78	7680

¹⁾ Dimensions do not include cooling fan.

²⁾ Single module only.

³⁾ The depth is without control panels and options.

Type	Height mm	Width mm	Depth mm
RDCU control unit *)	282	126	41

*) Delivered with R7i to nxR8i

Nominal ratings	
$I_{\text{cont. max}}$	Rated current available continuously without overloadability at 40 °C.
I_{max}	Maximum output current. Available for 10 s at start, otherwise as long as allowed by drive temperature.
Typical ratings: No-overload use	
$P_{\text{cont. max}}$	Typical motor power in no-overload use.
Light-overload use	
I_N	Continuous current allowing 110% I_N for 1 min / 5 min at 40 °C.
P_N	Typical motor power in light-overload use.
Heavy-duty use	
I_{hd}	Continuous current allowing 150% I_{hd} for 1 min / 5 min at 40 °C.
P_{hd}	Typical motor power in heavy-duty use.

The current ratings are the same regardless of the supply voltage within one voltage range.

The ratings apply in 40 °C ambient temperature. In lower temperatures the ratings are higher (except I_{max}).

The rated current of the ACS800 must be higher than or equal to the rated motor current to achieve the rated motor power given in the table.

Ratings, types and voltages

ACS800-X04, supply module, $U_N = 500\text{ V}$



Nominal ratings				No-overload use	Light-overload use		Heavy-duty use		Heat dissipation kW	Type designation	Frame size
$I_{cont. max}$ A (AC)	$I_{cont. max}$ A (DC)	I_{max} A (DC)	S_N kVA	$P_{cont. max}$ kW (DC)	I_N A (DC)	P_N kW (DC)	I_{hd} A (DC)	P_{hd} kW (DC)			

$U_N = 500\text{ V}$ (Range 380 to 500 V). The power ratings are valid at nominal voltage 500 V.

IGBT supply module (ISU)

5.1	6.1	8.9	4.4	4.4	5.9	4.3	4.4	3.1	0.3	ACS800-204-0004-5	R2i + RLCL-01-5
10.8	13.0	18.9	9.3	9.2	12.5	9.2	9.4	6.7	0.6	ACS800-204-0009-5	R2i + RLCL-02-5
27.7	33.6	48.4	24.0	23.8	32.2	23.8	24.2	17.1	0.9	ACS800-204-0021-5	R3i + RLCL-03-5
39.2	47.4	68.7	33.9	33.6	45.5	33.6	34.3	24.3	1.5	ACS800-204-0031-5	R4i + RLCL-11-5
78.3	94.7	137.9	67.8	67.1	91.0	67.1	69.0	48.8	2.4	ACS800-204-0061-5	R5i + RLCL-12-5
180	218	327	156	154	210	148	163	115	4	ACS800-204-0165-5	R7i + ALCL-04-5
220	267	399	191	189	256	181	200	141	4.4	ACS800-204-0195-5	R7i + ALCL-05-5
270	327	475	234	231	314	222	245	173	6.2	ACS800-204-0230-5	R8i + ALCL-12-5
360	436	633	312	309	419	296	327	231	8.4	ACS800-204-0310-5	R8i + ALCL-13-5
450	546	792	390	386	524	370	408	289	10.6	ACS800-204-0390-5	R8i + ALCL-14-5
600	727	1056	520	514	698	494	544	385	14.9	ACS800-204-0520-5	R8i + ALCL-15-5
900	1091	1584	779	772	1048	741	816	577	21.2	ACS800-204-0780-5	2xR8i + ALCL-24-5
1176	1426	2069	1018	1008	1369	968	1067	754	28.9	ACS800-204-1020-5	2xR8i + ALCL-25-5
1746	2117	3072	1512	1497	2032	1437	1584	1120	42.7	ACS800-204-1510-5	3xR8i + 2xALCL-24-5
2304	2794	4054	1995	1975	2682	1896	2090	1478	56.1	ACS800-204-2000-5	4xR8i + 2xALCL-25-5
3420	4147	6017	2962	2932	3981	2815	3102	2193	83	ACS800-204-2960-5	6xR8i + 3xALCL-25-5

6-pulse diode supply unit (DSU)

286	350	462	247	229	335	219	280	183	1.5	ACS800-304-0320-7	D3
408	500	700	353	327	480	314	400	262	2.4	ACS800-304-0450-7	D3
571	700	924	495	458	670	439	560	367	3.8	ACS800-704-0640-7	D4
816	1000	1400	707	655	960	629	800	524	5	ACS800-704-0910-7	D4
1143	1400	1848	990	917	1340	877	1120	733	7.6	ACS800-704-1370-7	2xD4
1518	1860	2604	1315	1218	1790	1172	1490	976	10	ACS800-704-1810-7	2xD4
2278	2790	3906	1972	1827	2685	1758	2230	1460	15	ACS800-704-2720-7	3xD4
3037	3720	5208	2630	2436	3580	2344	2980	1951	20	ACS800-704-3630-7	4xD4
3796	4650	6510	3287	3045	4475	2930	3720	2436	25	ACS800-704-4540-7	5xD4

6-pulse regenerative thyristor supply unit (TSU)

981	1202	1947	850	792	1137	749	881	580	6.3	ACS800-404-0850-5	2xB4 + choke
1617	1980	3208	1400	1304	1872	1233	1450	955	10.2	ACS800-404-1400-5	2xB4 + choke
2449	3000	4860	2120	1976	2838	1869	2240	1478	16.5	ACS800-404-2120-5	2xB5 + choke
2858	3500	5670	2475	2305	3310	2180	2618	1724	20.8	ACS800-404-2600-5	2xB5 + choke

12-pulse diode supply unit (DSU)

571	700	924	495	458	670	439	560	367	3.8	ACS800-704-0640-7	D4
816	1000	1400	707	655	960	629	800	524	5	ACS800-704-0910-7	D4
1143	1400	1848	990	917	1340	877	1120	733	7.6	ACS800-704-1370-7	2xD4
1518	1860	2604	1315	1218	1790	1172	1490	976	10	ACS800-704-1810-7	2xD4
2278	2790	3906	1972	1827	2685	1758	2230	1460	15	ACS800-704-2720-7	3xD4
3037	3720	5208	2630	2436	3580	2344	2980	1951	20	ACS800-704-3630-7	4xD4
3796	4650	6510	3287	3045	4475	2930	3720	2436	25	ACS800-704-4540-7	5xD4

Dimensions

Frame size	Height mm	Width mm	Depth mm	Weight kg	Noise level dB(A)	Air flow m³/h
------------	--------------	-------------	-------------	--------------	----------------------	------------------

IGBT supply unit (ISU)

R2i	401	165	193	9	62	35
R3i	466	173	232	12	62	69
R4i	525	240	252	15	62	103
R5i	673	265	276	23	65	250
R7i ¹⁾	963	170	408	38	72 ⁴⁾	800
R8i	1397	245	596	130	74 ⁴⁾	1280
2xR8i	1397	245 ²⁾	596	260	76 ⁴⁾	2560
3xR8i	1397	245 ²⁾	596	390	78 ⁴⁾	3840
4xR8i	1397	245 ²⁾	596	520	78 ⁴⁾	5120
6xR8i	1397	245 ²⁾	596	780	80 ⁴⁾	7680

LCL-filter for IGBT supply unit (ISU)

RLCL-01-5	850	173	137	15	69	-
RLCL-02-5	850	173	137	15	69	-
RLCL-03-5	850	173	137	20	69	-
RLCL-11-5	920	265	169.5	40	69	-
RLCL-12-5	920	265	169.5	50	69	-
ALCL-0X-X	810	304	292	72	-	480
ALCL-1X-X	1397	240	499	180	-	400
ALCL-2X-X	1397	240	573	305	-	1280

Frame size	Height mm	Width mm	Depth mm	Weight kg	Noise level dB(A)	Air flow m³/h
------------	--------------	-------------	-------------	--------------	----------------------	------------------

6-pulse diode supply unit (DSU)

D3	1480	234	400 ³⁾	130	65	720
D4	1480	234	400 ³⁾	180	65	720
2XD4	1480	234 ²⁾	400 ³⁾	360	67	1440
3XD4	1480	234 ²⁾	400 ³⁾	540	68	2160
4XD4	1480	234 ²⁾	400 ³⁾	720	69	2880
5XD4	1480	234 ²⁾	400 ³⁾	900	70	3600

6-pulse regenerative thyristor supply unit (TSU)

2XB4	1808	340 ²⁾	430	110 ²⁾	72 ⁵⁾	2000
2XB5	1808	420 ²⁾	430	150 ²⁾	75 ⁵⁾	3400

DC chokes for 6-pulse regenerative supply unit (TSU)

choke B4	771	348	449	110	-	600
choke B5	991	348	449	150	-	700

12-pulse diode supply unit (DSU)

D4	1480	234	400 ³⁾	180	65	720
2XD4	1480	234 ²⁾	400 ³⁾	360	67	1440
3XD4	1480	234 ²⁾	400 ³⁾	540	68	2160
4XD4	1480	234 ²⁾	400 ³⁾	720	69	2880
5XD4	1480	234 ²⁾	400 ³⁾	900	70	3600

¹⁾ Dimensions do not include cooling fan.

²⁾ Single module only.

³⁾ Cable connections need additional space (about 200 mm) behind the module.

⁴⁾ Supply modules + filters.

⁵⁾ Supply modules + choke.

Ratings, types and voltages

ACS800-X04, drive module, $U_N = 690\text{ V}$

ACS800 - X04 - XXXX - 7 + XXXX

Nominal ratings		No-overload use	Light-overload use		Heavy-duty use		Heat dissipation kW	Type designation	Frame size
$I_{\text{cont. max}}$ A	I_{max} A	$P_{\text{cont. max}}$ kW	I_N A	P_N kW	I_{hd} A	P_{hd} kW			
$U_N = 690\text{ V}$ (Range 525 to 690 V). The power ratings are valid at nominal voltage 690 V.									
13	14	11	12	7.5	8.5	5.5	0.3	ACS800-104-0011-7	R4i
17	19	15	16	11	11	7.5	0.3	ACS800-104-0016-7	R4i
22	28	18.5	21	15	15	11	0.4	ACS800-104-0020-7	R4i
25	38	22	24	18.5	19	15	0.5	ACS800-104-0025-7	R4i
33	44	30	32	22	22	18.5	0.6	ACS800-104-0030-7	R4i
36	54	30	35	30	27	22	0.7	ACS800-104-0040-7	R4i
51	68	45	49	37	34	30	0.8	ACS800-104-0050-7	R5i
57	84	55	55	45	42	37	1	ACS800-104-0060-7	R5i
69	104	55	66	55	52	45	1.1	ACS800-104-0075-7	R7i
88	132	75	84	75	66	55	1.3	ACS800-104-0105-7	R7i
105	158	90	101	90	79	75	1.6	ACS800-104-0125-7	R7i
132	198	110	127	110	99	90	2	ACS800-104-0145-7	R7i
150	224	132	144	132	112	90	2.3	ACS800-104-0175-7	R7i
170	254	160	163	160	127	110	2	ACS800-104-0215-7	R7i
215	322	200	206	200	161	160	3.6	ACS800-104-0260-7	R8i
289	432	250	277	250	216	200	4.8	ACS800-104-0320-7	R8i
336	503	315	323	315	251	240	6.1	ACS800-104-0400-7	R8i
382	571	355	367	355	286	270	7	ACS800-104-0440-7	R8i
486	727	450	467	450	364	355	7.5	ACS800-104-0580-7	R8i
729	1091	710	700	710	545	500	13	ACS800-104-0870-7	2xR8i
953	1425	900	914	900	713	710	15	ACS800-104-1160-7	2xR8i
1414	2116	1400	1358	1400	1058	1000	22	ACS800-104-1740-7	3xR8i
1866	2792	1900	1792	1800	1396	1400	29	ACS800-104-2320-7	4xR8i
2321	3472	2300	2228	2200	1736	1600	35	ACS800-104-2900-7	5xR8i
2770	4144	2800	2659	2700	2072	2000	42	ACS800-104-3490-7	6xR8i

Dimensions

Frame size	Height mm	Width mm	Depth mm	Weight kg	Noise level dB(A)	Air flow m ³ /h
R2i	401	165	193 ³⁾	9	62	35
R3i	466	173	232 ³⁾	12	62	69
R4i	525	240	252 ³⁾	15	62	103
R5i	673	265	276 ³⁾	23	65	168
R7i ¹⁾	963	170	408	38	64	800
R8i	1397	245	596	130	72	1280
2xR8i	1397	245 ²⁾	596	260	74	2560
3xR8i	1397	245 ²⁾	596	390	76	3840
4xR8i	1397	245 ²⁾	596	520	76	5120
5xR8i	1397	245 ²⁾	596	650	77	6400
6xR8i	1397	245 ²⁾	596	780	78	7680

¹⁾ Dimensions do not include cooling fan.

²⁾ Single module only.

³⁾ The depth is without control panels and options.

Type designation	Height mm	Width mm	Depth mm
RDCU control unit *)	282	126	41

*) Delivered with R7i to nxR8i

Nominal ratings	
$I_{\text{cont. max}}$	Rated current available continuously without overloadability at 40 °C.
I_{max}	Maximum output current. Available for 10 s at start, otherwise as long as allowed by drive temperature.
Typical ratings: No-overload use	
$P_{\text{cont. max}}$	Typical motor power in no-overload use.
Light-overload use	
I_N	Continuous current allowing 110% I_N for 1 min / 5 min at 40 °C.
P_N	Typical motor power in light-overload use.
Heavy-duty use	
I_{hd}	Continuous current allowing 150% I_{hd} for 1 min / 5 min at 40 °C.
P_{hd}	Typical motor power in heavy-duty use.

The current ratings are the same regardless of the supply voltage within one voltage range.

The ratings apply in 40 °C ambient temperature. In lower temperatures the ratings are higher (except I_{max}).

The rated current of the ACS800 must be higher than or equal to the rated motor current to achieve the rated motor power given in the table.

Ratings, types and voltages

ACS800-X04, supply module, $U_N = 690\text{ V}$

ACS800 - X04 - XXXX - 7 + XXXX

Nominal ratings				No-overload use	Light-overload use		Heavy-duty use		Heat dissipation kW	Type designation	Frame size
$I_{\text{cont. max}}$ A (AC)	$I_{\text{cont. max}}$ A (DC)	I_{max} A (DC)	S_N kVA	$P_{\text{cont. max}}$ kW (DC)	I_N A (DC)	P_N kW (DC)	I_{hd} A (DC)	P_{hd} kW (DC)			

$U_N = 690\text{ V}$ (Range 525 to 690 V). The power ratings are valid at nominal voltage 690 V.

IGBT supply module (ISU)											
119	144	216	142	141	139	135	108	105	4.6	ACS800-204-0155-7	R7i + ALCL-04-7
135	164	245	161	160	157	153	122	119	5.2	ACS800-204-0175-7	R7i + ALCL-05-7
180	218	327	215	213	210	204	163	159	8.3	ACS800-204-0220-7	R8i + ALCL-12-7
250	303	453	299	296	291	284	227	221	9.4	ACS800-204-0300-7	R8i + ALCL-13-7
300	364	544	359	355	349	341	272	266	13.3	ACS800-204-0360-7	R8i + ALCL-14-7
400	485	726	478	473	466	454	363	354	14.6	ACS800-204-0480-7	R8i + ALCL-15-7
600	727	1088	717	710	698	682	544	531	26.6	ACS800-204-0720-7	2xR8i + ALCL-24-7
784	951	1422	937	928	913	890	711	694	28.5	ACS800-204-0940-7	2xR8i + ALCL-25-7
1164	1411	2111	1391	1377	1355	1322	1056	1030	42.3	ACS800-204-1390-7	3xR8i + 2xALCL-24-5
1536	1862	2786	1836	1817	1788	1745	1393	1359	55.7	ACS800-204-1840-7	4xR8i + 2xALCL-25-7
2280	2764	4136	2725	2698	2654	2590	2068	2018	83	ACS800-204-2730-7	6xR8i + 3xALCL-25-7

6-pulse diode supply unit (DSU)											
286	350	462	341	316	335	303	280	253	1.5	ACS800-304-0320-7	D3
408	500	700	488	452	480	434	400	361	2.4	ACS800-304-0450-7	D3
571	700	924	683	632	670	605	560	506	3.8	ACS800-704-0640-7	D4
816	1000	1400	976	904	960	867	800	723	5	ACS800-704-0910-7	D4
1143	1400	1848	1366	1265	1340	1211	1120	1012	7.6	ACS800-704-1370-7	2xD4
1518	1860	2604	1815	1681	1790	1617	1490	1346	10	ACS800-704-1810-7	2xD4
2278	2790	3906	2722	2521	2685	2426	2230	2015	15	ACS800-704-2720-7	3xD4
3037	3720	5208	3629	3361	3580	3235	2980	2693	20	ACS800-704-3630-7	4xD4
3796	4650	6510	4537	4202	4475	4043	3720	3361	25	ACS800-704-4540-7	5xD4

6-pulse regenerative thyristor supply unit (TSU)											
711	871	1411	850	784	824	742	637	574	6.3	ACS800-404-0850-7	2xB4 + choke
1171	1435	2325	1400	1292	1353	1219	1050	946	10.2	ACS800-404-1400-7	2xB4 + choke
2176	2664	4316	2600	2399	2519	2269	1993	1795	16.5	ACS800-404-2600-7	2xB5 + choke
2858	3500	5670	3415	3152	3311	2982	2618	2358	20.8	ACS800-404-3600-7	2xB5 + choke

12-pulse diode supply unit (DSU)											
571	700	924	683	632	670	605	560	506	3.8	ACS800-704-0640-7	D4
816	1000	1400	976	904	960	867	800	723	5	ACS800-704-0910-7	D4
1143	1400	1848	1366	1265	1340	1211	1120	1012	7.6	ACS800-704-1370-7	2xD4
1518	1860	2604	1815	1681	1790	1617	1490	1346	10	ACS800-704-1810-7	2xD4
2278	2790	3906	2722	2521	2685	2426	2230	2015	15	ACS800-704-2720-7	3xD4
3037	3720	5208	3629	3361	3580	3235	2980	2693	20	ACS800-704-3630-7	4xD4
3796	4650	6510	4537	4202	4475	4043	3720	3361	25	ACS800-704-4540-7	5xD4

Dimensions

Frame size	Height mm	Width mm	Depth mm	Weight kg	Noise level dB(A)	Air flow m³/h
IGBT supply unit (ISU)						
R7i ¹⁾	963	170	408	38	72 ⁴⁾	800
R8i	1397	245	596	130	74 ⁴⁾	1280
2xR8i	1397	245 ²⁾	596	260	76 ⁴⁾	2560
3xR8i	1397	245 ²⁾	596	390	78 ⁴⁾	3840
4xR8i	1397	245 ²⁾	596	520	78 ⁴⁾	5120
6xR8i	1397	245 ²⁾	596	780	80 ⁴⁾	7680
LCL-filter for IGBT supply unit (ISU)						
ALCL-0X-X	810	304	292	72	-	480
ALCL-1X-X	1397	240	499	180	-	400
ALCL-2X-X	1397	240	573	305	-	1280
6-pulse diode supply unit (DSU)						
D3	1480	234	400 ³⁾	130	65	720
D4	1480	234	400 ³⁾	180	65	720
2XD4	1480	234 ²⁾	400 ³⁾	360	67	1440
3XD4	1480	234 ²⁾	400 ³⁾	540	68	2160
4XD4	1480	234 ²⁾	400 ³⁾	720	69	2880
5XD4	1480	234 ²⁾	400 ³⁾	900	70	3600

¹⁾ Dimensions do not include cooling fan.

²⁾ Single module only.

³⁾ Cable connections need additional space (about 200 mm) behind the module.

⁴⁾ Supply modules + filters.

⁵⁾ Supply modules + choke.

Frame size	Height mm	Width mm	Depth mm	Weight kg	Noise level dB(A)	Air flow m³/h
6-pulse regenerative thyristor supply unit (TSU)						
2XB4	1808	340 ²⁾	430	110 ²⁾	72 ⁵⁾	2000
2XB5	1808	420 ²⁾	430	150 ²⁾	75 ⁵⁾	3400
DC chokes for 6-pulse regenerative supply unit (TSU)						
choke B4	771	348	449	110	-	600
choke B5	991	348	449	150	-	700
12-pulse diode supply unit (DSU)						
D4	1480	234	400 ³⁾	180	65	720
2XD4	1480	234 ²⁾	400 ³⁾	360	67	1440
3XD4	1480	234 ²⁾	400 ³⁾	540	68	2160
4XD4	1480	234 ²⁾	400 ³⁾	720	69	2880
5XD4	1480	234 ²⁾	400 ³⁾	900	70	3600

Nominal ratings

$I_{\text{cont. max}}$	Rated current available continuously without overloadability at 40 °C.
I_{max}	Maximum output current.
S_N	Nominal apparent power.
Typical ratings: No-overload use	
$P_{\text{cont. max}}$	Power in no-overload use.
Light-overload use	
I_N	Continuous current allowing 110% I_N for 1 min / 5 min at 40 °C.
P_N	Power in light-overload use.
Heavy-duty use	
I_{hd}	Continuous current allowing 150% I_{hd} for 1 min / 5 min at 40 °C.
P_{hd}	Power in heavy-duty use.

The current ratings are the same regardless of the supply voltage within one voltage range.

The ratings apply in 40 °C ambient temperature. In lower temperatures the ratings are higher (except I_{max}).

Liquid-cooled modules

ACS800-04LC/-X04LC



Solutions for high power drives

The liquid-cooled ACS800 frequency converter modules offer robust design for high-power applications. The liquid-cooled ACS800 product family provides advanced reliability and availability in all industry sectors.

Customer specific design

The liquid-cooled ACS800 is available for single and system drive purposes. The modular hardware design and advanced software features enable the most sophisticated drive solutions. Our customised solutions provide the optimum customer benefits for any demanding application. Our product know-how is at your service.

Advanced liquid-cooling

The ACS800 can utilize direct liquid-cooling which makes the converter extremely compact and silent. Liquid-cooling reduces the need for high-power filtered air cooling in the installation rooms. Along with the high efficiency, direct liquid-cooling offers low noise and easy heat transfer without air filtering problems.

Support for cabinet assembly

A full selection of both mechanical and electrical installation kits is available for liquid-cooled ACS800 frequency converter modules. These make cabinet installation into RITTAL TS8 cabinets efficient and easy. A large variety of support material such as dimensional drawings and circuit diagrams is also available for making cabinet assembly, planning and implementation as straightforward and rapid as possible. It is also possible to use optional installation racks instead of cabinets. Installation racks are a compact and cost efficient way to assemble a full liquid-cooled ACS800 frequency converter drive system inside a closed environment such as, for example, a container without an existing air-conditioning system.

Full selection of drive module products

The liquid-cooled ACS800 frequency converter module product family includes diode and regenerative IGBT supply units, a large variety of inverter units, high power dynamic braking unit modules, and liquid cooling units for all demanding customer needs. Both diode supply units and regenerative IGBT supply units are available with a wide power range and high power density. When high capacity braking is needed and the drive cannot be equipped with a regenerative supply unit, it is possible to use three-phase liquid-cooled dynamic braking unit modules. With a liquid cooling unit it is possible to add supply, inverter and brake unit piping and heat exchangers to the same closed-loop cooling system. The liquid-cooled modules are available in both multidrive and single drive modules.



Ratings, types and voltages

ACS800-04LC, single drive module, $U_N = 400$ to 690 V



Nominal ratings		No-overload use	Light-overload use		Heavy-duty use		Heat dissipation kW	Mass flow ¹⁾ l/min	Type designation	Frame size
$I_{cont. max}$ A	I_{max} A	$P_{cont. max}$ kW	I_N A	P_N kW	I_{hd} A	P_{hd} kW				
$U_N = 400$ V (Range 380 to 415 V) The power ratings are valid at nominal voltage 400 V.										
563	674	315	540	315	421	200	8.7	32	ACS800-04LC-0390-3	1xD3 + 1xR8i
678	837	355	651	355	507	250	10	32	ACS800-04LC-0470-3	1xD3 + 1xR8i
889	1037	500	853	400	665	355	14	32	ACS800-04LC-0620-3	1xD3 + 1xR8i
1103	1279	630	1059	560	825	450	16	45	ACS800-04LC-0760-3	1xD4 + 2xR8i
1329	1590	710	1276	710	994	500	21	45	ACS800-04LC-0920-3	1xD4 + 2xR8i
1742	1994	900	1673	900	1303	710	26	45	ACS800-04LC-1210-3	1xD4 + 2xR8i
1973	2347	1120	1894	1120	1476	900	28	77	ACS800-04LC-1370-3	2xD4 + 3xR8i
2587	2941	1400	2484	1400	1935	1120	37	77	ACS800-04LC-1790-3	2xD4 + 3xR8i
3414	3906	2000	3277	2000	2553	1400	51	90	ACS800-04LC-2370-3	2xD4 + 4xR8i
$U_N = 500$ V (Range 380 to 500 V). The power ratings are valid at nominal voltage 500 V.										
546	673	355	524	355	408	315	8.7	32	ACS800-04LC-0470-5	1xD3 + 1xR8i
630	838	400	605	400	471	355	10	32	ACS800-04LC-0550-5	1xD3 + 1xR8i
840	1042	560	806	560	628	400	13	32	ACS800-04LC-0730-5	1xD3 + 1xR8i
1070	1280	710	1027	710	800	560	16	45	ACS800-04LC-0930-5	1xD4 + 2xR8i
1235	1589	900	1185	900	924	630	19	45	ACS800-04LC-1070-5	1xD4 + 2xR8i
1646	1996	1120	1581	1120	1232	710	25	45	ACS800-04LC-1430-5	1xD4 + 2xR8i
1833	2344	1250	1760	1250	1371	900	29	58	ACS800-04LC-1590-5	1xD4 + 3xR8i
2444	2943	1600	2347	1600	1828	1250	36	77	ACS800-04LC-2120-5	2xD4 + 3xR8i
3226	3885	2240	3097	2240	2413	1600	49	90	ACS800-04LC-2790-5	2xD4 + 4xR8i
$U_N = 690$ V (Range 525 to 690 V). The power ratings are valid at nominal voltage 690 V.										
583	872	560	560	500	436	400	12	32	ACS800-04LC-0700-7	1xD3 + 1xR8i
790	1182	710	759	710	591	560	17	45	ACS800-04LC-0940-7	1xD3 + 2xR8i
898	1344	900	863	900	672	630	19	45	ACS800-04LC-1070-7	1xD3 + 2xR8i
1143	1710	1120	1097	1120	855	710	22	45	ACS800-04LC-1370-7	1xD4 + 2xR8i
1334	1996	1250	1281	1250	998	900	28	58	ACS800-04LC-1590-7	1xD4 + 3xR8i
1697	2538	1600	1629	1600	1269	1250	34	58	ACS800-04LC-2030-7	1xD4 + 3xR8i
2239	3350	2240	2150	2000	1675	1600	44	90	ACS800-04LC-2680-7	2xD4 + 4xR8i

¹⁾ Pressure loss 100 kPa. Hydrostatic pressure loss 120 kPa due to 2 m height difference.

Dimensions

Frame size	Height mm	Width mm	Depth ¹⁾ mm	Weight kg
D3	975	311	474	140
D4	975	311	474	210
R8i	918	214	478	115

Nominal ratings	
$I_{cont. max}$	Rated current available continuously without overloadability at 42 °C liquid temperature.
I_{max}	Maximum output current. Available for 10 s at start, otherwise as long as allowed by drive temperature. Note: max. motor shaft power is 150% P_{hd} .
Typical ratings: No-overload use	
$P_{cont. max}$	Typical motor power in no-overload use.
Light-overload use	
I_N	Continuous base current allowing 110% overload for 1 min /5 min.
P_N	Typical motor power in light-overload use.
Heavy-duty use	
I_{hd}	Continuous base current allowing 150% overload for 1 min /5 min.
P_{hd}	Typical motor power in heavy-duty use.
Losses	
P_{loss}	Power loss conducted to coolant.

The current ratings are the same regardless of the supply voltage within one voltage range.

Ratings, types and voltages

ACS800-X04LC, drive module, $U_N = 400\text{ V}$

ACS800 - X04LC - XXXX - 3 + XXXX

Inverter unit modules (INU)

Nominal ratings		No-overload use		Light-overload use		Heavy-duty use		Losses ¹⁾		Mass flow ²⁾	Type designation	Frame size
$I_{cont,max}$ A	I_{max} A	$P_{cont,max}$ kW	I_N A	P_N kW	I_{hd} A	P_{hd} kW	P_{loss} kW		l/min			
$U_N = 400\text{ V}$ (Range 380 to 415 V). The power ratings are valid at nominal voltage 400 V.												
5.1	6.5	1.5	4.7	1.5	3.4	1.1	0.1		6	ACS800-104LC-0003-3	R2i	
6.5	8.2	2.2	5.9	2.2	4.3	1.5	0.1		6	ACS800-104LC-0004-3	R2i	
8.5	10.8	3	7.7	3	5.7	2.2	0.1		6	ACS800-104LC-0005-3	R2i	
10.9	13.8	4	10.2	4	7.5	3	0.1		6	ACS800-104LC-0006-3	R2i	
13.9	17.6	5.5	12.7	5.5	9.3	4	0.2		6	ACS800-104LC-0009-3	R2i	
19	24	7.5	18	7.5	14	5.5	0.3		6	ACS800-104LC-0011-3	R3i	
25	32	11	24	11	19	7.5	0.3		6	ACS800-104LC-0016-3	R3i	
34	46	15	31	15	23	11	0.4		6	ACS800-104LC-0020-3	R3i	
44	62	22	41	18.5	32	15	0.5		6	ACS800-104LC-0025-3	R4i	
55	72	30	50	22	37	18.5	0.6		6	ACS800-104LC-0030-3	R4i	
72	86	37	69	30	49	22	0.8		6	ACS800-104LC-0040-3	R5i	
86	112	45	80	37	60	30	1.0		6	ACS800-104LC-0050-3	R5i	
103	138	55	94	45	69	37	1.2		6	ACS800-104LC-0060-3	R5i	
176	251	90	169	90	132	55	1.6		13	ACS800-104LC-0120-3	R7i	
214	251	110	205	110	160	75	2.1		13	ACS800-104LC-0150-3	R7i	
250	335	132	240	132	187	90	2.3		13	ACS800-104LC-0170-3	R7i	
300	448	160	288	160	224	110	2.6		13	ACS800-104LC-0210-3	R7i	
350	524	200	336	200	262	132	3.8		13	ACS800-104LC-0240-3	R8i	
444	558	250	426	250	332	160	5.0		13	ACS800-104LC-0310-3	R8i	
563	674	315	540	315	421	200	5.9		13	ACS800-104LC-0390-3	R8i	
678	837	355	651	355	507	250	7.3		13	ACS800-104LC-0470-3	R8i	
889	1037	500	853	400	665	355	9.2		13	ACS800-104LC-0620-3	R8i	
1103	1279	630	1059	560	825	450	11.4		26	ACS800-104LC-0760-3	2xR8i	
1329	1590	710	1276	710	994	500	14.2		26	ACS800-104LC-0920-3	2xR8i	
1742	1994	900	1673	900	1303	710	17.9		26	ACS800-104LC-1210-3	2xR8i	
1973	2347	1120	1894	1120	1476	900	20.9		39	ACS800-104LC-1370-3	3xR8i	
2587	2941	1400	2484	1400	1935	1120	26.6		39	ACS800-104LC-1790-3	3xR8i	
3414	3906	2000	3277	2000	2553	1400	34.8		52	ACS800-104LC-2370-3	4xR8i	

Nominal ratings				No-overload use	Light-overload use	Heavy-duty use	Losses ¹⁾				Mass flow ²⁾	Type designation	Frame size		
$I_{cont,max}$ A (AC)	$I_{cont,max}$ A (DC)	I_{max} A (DC)	S_N kVA	$P_{cont,max}$ kW (DC)	I_N A (DC)	P_N kW	I_{hd} A (DC)	P_{hd} kW	P_{loss} kW	P_{lossSU} kW	$P_{lossLCL}$ kW	$P_{loss tot}$ kW	l/min		

$U_N = 400\text{ V}$ (Range 380 to 415 V). The power ratings are valid at nominal 400 V.

IGBT supply unit modules (ISU)

341	413	471	245	243	397	233	309	181	-	4.4	3.0	7.4	22	ACS800-204LC-0240-3	R8i
454	550	627	326	323	528	310	411	241	-	5.6	3.1	8.7	22	ACS800-204LC-0330-3	R8i
567	687	784	408	403	660	387	514	302	-	6.7	3.4	10.1	22	ACS800-204LC-0410-3	R8i
756	917	1046	543	538	880	516	686	402	-	8.9	4.0	12.9	22	ACS800-204LC-0540-3	R8i
1134	1375	1568	815	807	1320	775	1028	604	-	13.5	5.6	19.1	40	ACS800-204LC-0820-3	2xR8i
1482	1797	2049	1065	1054	1725	1012	1344	789	-	17.3	7.9	25.3	40	ACS800-204LC-1070-3	2xR8i
2200	2667	3042	1581	1565	2560	1503	1995	1171	-	25.7	12.0	37.8	66	ACS800-204LC-1580-3	3xR8i
2903	3520	4015	2087	2066	3379	1983	2633	1545	-	33.8	15.8	49.7	80	ACS800-204LC-2090-3	4xR8i

6-pulse, diode supply unit modules (DSU)

572	700	980	396	378	672	363	560	303	3.6	-	-	-	19	ACS800-304LC-0680-7	1xD3
898	1100	1540	622	594	1056	570	880	475	5.9	-	-	-	19	ACS800-304LC-1070-7	1xD3
1143	1400	1960	792	756	1344	726	1120	605	7.2	-	-	-	19	ACS800-704LC-1370-7	1xD4
1796	2200	3080	1245	1188	2112	1141	1760	951	11.8	-	-	-	19	ACS800-704LC-2150-7	1xD4
2126	2604	3646	1473	1407	2500	1350	2083	1125	13.0	-	-	-	38	ACS800-704LC-2540-7	2xD4
3200	3919	5487	2217	2117	3762	2032	3135	1694	19.7	-	-	-	38	ACS800-704LC-3820-7	2xD4

12-pulse, diode supply unit modules (DSU)

1143	1400	1960	792	756	1344	726	1120	605	7.2	-	-	-	19	ACS800-704LC-1370-7	1xD4
1796	2200	3080	1245	1188	2112	1141	1760	951	11.8	-	-	-	19	ACS800-704LC-2150-7	1xD4
2126	2604	3646	1473	1407	2500	1350	2083	1125	13.0	-	-	-	38	ACS800-704LC-2540-7	2xD4
3200	3919	5487	2217	2117	3762	2032	3135	1694	19.7	-	-	-	38	ACS800-704LC-3820-7	2xD4

¹⁾ In totally enclosed cabinet 98% of losses are conducted to coolant, 2% to ambient air.
²⁾ Pressure loss 100 kPa. Hydrostatic pressure loss 120 kPa due to 2 m height difference.

Nominal ratings	
$I_{cont,max}$	Rated current available continuously without overloadability at 42 °C liquid temperature.
I_{max}	Maximum output current. Available for 10 s at start, otherwise as long as allowed by drive temperature. Note: max. motor shaft power is 150% P_{hd} .
S_N	Nominal apparent power.
No-overload use	
$P_{cont,max}$	Typical motor power in no-overload use.
Light-overload use	
I_N	Continuous base current allowing 110% overload for 1 min /5 min.
P_N	Typical motor power in light-overload use.

Heavy-duty use	
I_{hd}	Continuous base current allowing 150% overload for 1 min /5 min.
P_{hd}	Typical motor power in heavy-duty use.
Losses	
P_{loss}	Power loss conducted to coolant.
P_{lossSU}	Power loss of supply module(s).
$P_{lossLCL}$	Power loss of supply LCL filter.
$P_{loss tot}$	Sum of P_{lossSU} and $P_{lossLCL}$.

The current ratings are the same regardless of the supply voltage within one voltage range.

Ratings, types and voltages

ACS800-X04LC, drive module, $U_N = 500\text{ V}$

ACS800 - X04LC - XXXX - 5 + XXXX

Inverter unit modules (INU)

Nominal ratings		No-overload use		Light-overload use		Heavy-duty use		Losses ¹⁾		Mass flow ²⁾	Type designation	Frame size
$I_{cont,max}$ A	I_{max} A	$P_{cont,max}$ kW	I_N A	P_N kW	I_{hd} A	P_{hd} kW	P_{loss} kW		l/min			
$U_N = 500\text{ V}$ (Range 380 to 500 V). The power ratings are valid at nominal voltage 500 V.												
4.9	6.5	2.2	4.5	2.2	3.4	1.5	0.1		6		ACS800-104LC-0004-5	R2i
6.2	8.2	3	5.6	3	4.2	2.2	0.1		6		ACS800-104LC-0005-5	R2i
8.1	10.8	4	7.7	4	5.6	3	0.2		6		ACS800-104LC-0006-5	R2i
10.5	13.8	5.5	10	5.5	7.5	4	0.2		6		ACS800-104LC-0009-5	R2i
13.2	17.6	7.5	12	7.5	9.2	5.5	0.3		6		ACS800-104LC-0011-5	R2i
19	24	11	18	11	13	7.5	0.3		6		ACS800-104LC-0016-5	R3i
25	32	15	23	15	18	11	0.4		6		ACS800-104LC-0020-5	R3i
34	46	18.5	31	18.5	23	15	0.5		6		ACS800-104LC-0025-5	R3i
42	62	22	39	22	32	18.5	0.6		6		ACS800-104LC-0030-5	R4i
48	72	30	44	30	36	22	0.8		6		ACS800-104LC-0040-5	R4i
65	86	37	61	37	50	30	1.0		6		ACS800-104LC-0050-5	R5i
79	112	45	75	45	60	37	1.2		6		ACS800-104LC-0060-5	R5i
96	138	55	88	55	69	45	1.4		6		ACS800-104LC-0070-5	R5i
138	206	90	132	90	103	55	1.3		13		ACS800-104LC-0120-5	R7i
162	242	110	156	110	121	75	1.6		13		ACS800-104LC-0140-5	R7i
199	252	132	191	132	149	90	2.0		13		ACS800-104LC-0170-5	R7i
250	335	160	240	160	187	110	2.5		13		ACS800-104LC-0220-5	R7i
300	448	200	288	200	224	160	2.7		13		ACS800-104LC-0260-5	R7i
378	558	250	363	250	283	200	4.4		13		ACS800-104LC-0330-5	R8i
438	558	315	420	315	328	250	5.2		13		ACS800-104LC-0380-5	R8i
546	673	355	524	355	408	315	6.0		13		ACS800-104LC-0470-5	R8i
630	838	400	605	400	471	355	7.0		13		ACS800-104LC-0550-5	R8i
840	1042	560	806	560	628	400	8.9		13		ACS800-104LC-0730-5	R8i
1070	1280	710	1027	710	800	560	11.5		26		ACS800-104LC-0930-5	2xR8i
1235	1589	900	1185	900	924	630	13.6		26		ACS800-104LC-1070-5	2xR8i
1646	1996	1120	1581	1120	1232	710	17.4		26		ACS800-104LC-1430-5	2xR8i
1833	2344	1250	1760	1250	1371	900	20.1		39		ACS800-104LC-1590-5	3xR8i
2444	2943	1600	2347	1600	1828	1250	25.9		39		ACS800-104LC-2120-5	3xR8i
3226	3885	2240	3097	2240	2413	1600	33.8		52		ACS800-104LC-2790-5	4xR8i

Nominal ratings				No-overload use	Light-overload use	Heavy-duty use	Losses ¹⁾				Mass flow ²⁾	Type designation	Frame size		
$I_{cont,max}$ A (AC)	$I_{cont,max}$ A (DC)	I_{max} A (DC)	S_N kVA	$P_{cont,max}$ kW (DC)	I_N A (DC)	P_N kW	I_{hd} A (DC)	P_{hd} kW	P_{loss} kW	P_{lossSU} kW	$P_{lossLCL}$ kW	$P_{loss tot}$ kW	l/min		

$U_N = 500\text{ V}$ (Range 380 to 500 V). The power ratings are valid at nominal 500 V.

IGBT supply unit modules (ISU)

324	393	475	281	278	377	267	294	208	-	4.5	3.0	7.5	22	ACS800-204LC-0280-5	R8i
432	524	633	374	370	503	356	392	277	-	5.7	3.1	8.8	22	ACS800-204LC-0370-5	R8i
540	655	792	468	463	629	444	490	346	-	6.8	3.4	10.2	22	ACS800-204LC-0470-5	R8i
720	873	1056	624	617	838	593	653	462	-	9.0	4.0	13.0	22	ACS800-204LC-0620-5	R8i
1080	1309	1584	935	926	1257	889	980	693	-	13.7	5.6	19.3	40	ACS800-204LC-0940-5	2xR8i
1411	1711	2069	1222	1210	1643	1162	1280	905	-	17.6	7.9	25.5	40	ACS800-204LC-1220-5	2xR8i
2095	2540	3072	1814	1796	2439	1724	1900	1344	-	26.1	12.0	38.2	66	ACS800-204LC-1810-5	3xR8i
2765	3352	4054	2394	2370	3218	2276	2508	1773	-	34.3	15.8	50.2	80	ACS800-204LC-2390-5	4xR8i

6-pulse, diode supply unit modules (DSU)

572	700	980	396	378	672	363	560	303	3.6	-	-	-	19	ACS800-304LC-0680-7	1xD3
898	1100	1540	622	594	1056	570	880	475	5.9	-	-	-	19	ACS800-304LC-1070-7	1xD3
1143	1400	1960	792	756	1344	726	1120	605	7.2	-	-	-	19	ACS800-704LC-1370-7	1xD4
1796	2200	3080	1245	1188	2112	1141	1760	951	11.8	-	-	-	19	ACS800-704LC-2150-7	1xD4
2126	2604	3646	1473	1407	2500	1350	2083	1125	13.0	-	-	-	38	ACS800-704LC-2540-7	2xD4
3200	3919	5487	2217	2117	3762	2032	3135	1694	19.7	-	-	-	38	ACS800-704LC-3820-7	2xD4

12-pulse, diode supply unit modules (DSU)

1143	1400	1960	990	945	1344	908	1120	756	7.2	-	-	-	19	ACS800-704LC-1370-7	1xD4
1796	2200	3080	1556	1486	2112	1426	1760	1188	11.8	-	-	-	19	ACS800-704LC-2150-7	1xD4
2126	2604	3646	1841	1758	2500	1688	2083	1407	13.0	-	-	-	38	ACS800-704LC-2540-7	2xD4
3200	3919	5487	2771	2646	3762	2540	3135	2117	19.7	-	-	-	38	ACS800-704LC-3820-7	2xD4

¹⁾ In totally enclosed cabinet 98% of losses are conducted to coolant, 2% to ambient air.

²⁾ Pressure loss 100 kPa. Hydrostatic pressure loss 120 kPa due to 2 m height difference.

Nominal ratings	
$I_{cont,max}$	Rated current available continuously without overloadability at 42 °C liquid temperature.
I_{max}	Maximum output current. Available for 10 s at start, otherwise as long as allowed by drive temperature. Note: max. motor shaft power is 150% P_{hd} .
S_N	Nominal apparent power.
No-overload use	
$P_{cont,max}$	Typical motor power in no-overload use.

Light-overload use	
I_N	Continuous base current allowing 110% overload for 1 min /5 min.
P_N	Typical motor power in light-overload use.
Heavy-duty use	
I_{hd}	Continuous base current allowing 150% overload for 1 min /5 min.
P_{hd}	Typical motor power in heavy-duty use.
Losses	
P_{loss}	Power loss conducted to coolant.
P_{lossSU}	Power loss of supply module(s).
$P_{lossLCL}$	Power loss of supply LCL filter.
$P_{loss tot}$	Sum of P_{lossSU} and $P_{lossLCL}$.

The current ratings are the same regardless of the supply voltage within one voltage range.

Ratings, types and voltages

ACS800-X04LC, drive module, $U_N = 690\text{ V}$

ACS800 - X04LC - XXXX - 7 + XXXX

Inverter unit modules (INU)

Nominal ratings		No-overload use		Light-overload use		Heavy-duty use		Losses ¹⁾			Mass flow ²⁾	Type designation	Frame size
$I_{cont.max}$	I_{max}	$P_{cont.max}$	I_N	P_N	I_{hd}	P_{hd}	P_{loss}				l/min		
A	A	kW	A	kW	A	kW	kW						
$U_N = 690\text{ V}$ (Range 525 to 690 V). The power ratings are valid at nominal voltage 690 V.													
13	14	11	12	7.5	8.5	5.5	0.3	6				ACS800-104LC-0011-7	R4i
17	19	15	16	11	11	7.5	0.3	6				ACS800-104LC-0016-7	R4i
22	28	18.5	21	15	15	11	0.4	6				ACS800-104LC-0020-7	R4i
25	38	22	24	18.5	19	15	0.5	6				ACS800-104LC-0025-7	R4i
33	44	30	32	22	22	18.5	0.6	6				ACS800-104LC-0030-7	R4i
36	54	30	35	30	27	22	0.7	6				ACS800-104LC-0040-7	R4i
51	68	45	49	37	34	30	0.8	6				ACS800-104LC-0050-7	R5i
57	84	55	55	45	42	37	1.0	6				ACS800-104LC-0060-7	R5i
83	124	75	79	55	62	55	1.2	13				ACS800-104LC-0100-7	R7i
106	158	90	101	90	79	75	1.6	13				ACS800-104LC-0130-7	R7i
126	188	110	121	110	94	90	1.8	13				ACS800-104LC-0150-7	R7i
158	236	132	152	132	118	110	2.4	13				ACS800-104LC-0190-7	R7i
180	270	160	173	160	135	132	2.7	13				ACS800-104LC-0220-7	R7i
204	306	200	196	200	153	160	2.4	13				ACS800-104LC-0240-7	R7i
258	386	250	248	250	193	200	4.8	13				ACS800-104LC-0310-7	R8i
347	518	315	333	315	259	250	5.5	13				ACS800-104LC-0410-7	R8i
403	604	355	387	355	302	315	6.4	13				ACS800-104LC-0480-7	R8i
458	686	450	440	400	343	355	8.2	13				ACS800-104LC-0550-7	R8i
583	872	560	560	500	436	400	8.9	13				ACS800-104LC-0700-7	R8i
790	1182	710	759	710	591	560	12.7	26				ACS800-104LC-0940-7	2xR8i
898	1344	900	863	900	672	630	15.9	26				ACS800-104LC-1070-7	2xR8i
1143	1710	1120	1097	1120	855	710	17.4	26				ACS800-104LC-1370-7	2xR8i
1334	1996	1250	1281	1250	998	900	24.0	39				ACS800-104LC-1590-7	3xR8i
1697	2538	1600	1629	1600	1269	1250	25.8	39				ACS800-104LC-2030-7	3xR8i
2239	3350	2240	2150	2000	1675	1600	34.3	52				ACS800-104LC-2680-7	4xR8i

Nominal ratings				No-overload use	Light-overload use	Heavy-duty use	Losses ¹⁾				Mass flow ²⁾	Type designation	Frame size		
$I_{cont.max}$	$I_{cont.max}$	I_{max}	S_N	$P_{cont.max}$	I_N	P_N	I_{hd}	P_{hd}	P_{loss}	P_{lossSU}	$P_{lossLCL}$	$P_{loss tot}$	l/min		
A (AC)	A (DC)	A (DC)	kVA	kW (DC)	A (DC)	kW	A (DC)	kW	kW	kW	kW	kW			
$U_N = 690\text{ V}$ (Range 525 to 690 V). The power ratings are valid at nominal 690 V.															
IGBT supply unit modules (ISU)															
216	262	386	258	256	251	245	196	191	-	5.0	2.6	7.6	22	ACS800-204LC-0260-7	R8i
300	364	604	359	355	349	341	272	266	-	5.6	3.1	8.7	22	ACS800-204LC-0360-7	R8i
360	436	686	430	426	419	409	327	319	-	7.6	3.4	11.0	22	ACS800-204LC-0430-7	R8i
480	582	872	574	568	559	545	435	425	-	8.3	4.3	12.6	22	ACS800-204LC-0570-7	R8i
720	873	1344	860	852	838	818	653	637	-	15.2	4.4	19.6	40	ACS800-204LC-0860-7	2xR8i
941	1141	1710	1124	1113	1095	1069	853	833	-	16.2	6.7	22.9	40	ACS800-204LC-1120-7	2xR8i
1397	1694	2538	1669	1653	1626	1587	1267	1236	-	24.1	7.4	31.5	58	ACS800-204LC-1670-7	3xR8i
1843	2235	3350	2203	2181	2145	2094	1672	1631	-	31.8	13.4	45.2	80	ACS800-204LC-2200-7	4xR8i
6-pulse, diode supply unit modules (DSU)															
572	700	980	683	652	672	626	560	522	3.6	-	-	-	19	ACS800-304LC-0680-7	1xD3
898	1100	1540	1073	1025	1056	984	880	820	5.9	-	-	-	19	ACS800-304LC-1070-7	1xD3
1143	1400	1960	1366	1305	1344	1252	1120	1044	7.2	-	-	-	19	ACS800-704LC-1370-7	1xD4
1796	2200	3080	2147	2050	2112	1968	1760	1640	11.8	-	-	-	19	ACS800-704LC-2150-7	1xD4
2126	2604	3646	2541	2426	2500	2329	2083	1941	13.0	-	-	-	38	ACS800-704LC-2540-7	2xD4
3200	3919	5487	3824	3652	3762	3506	3135	2921	19.7	-	-	-	38	ACS800-704LC-3820-7	2xD4
12-pulse, diode supply unit modules (DSU)															
1143	1400	1960	1366	1305	1344	1252	1120	1044	7.2	-	-	-	19	ACS800-704LC-1370-7	1xD4
1796	2200	3080	2147	2050	2112	1968	1760	1640	11.8	-	-	-	19	ACS800-704LC-2150-7	1xD4
2126	2604	3646	2541	2426	2500	2329	2083	1941	13.0	-	-	-	38	ACS800-704LC-2540-7	2xD4
3200	3919	5487	3824	3652	3762	3506	3135	2921	19.7	-	-	-	38	ACS800-704LC-3820-7	2xD4

¹⁾ In totally enclosed cabinet 98% of losses are conducted to coolant, 2% to ambient air.

²⁾ Pressure loss 100 kPa. Hydrostatic pressure loss 120 kPa due to 2 m height difference.

Nominal ratings	
$I_{cont.max}$	Rated current available continuously without overloadability at 42 °C liquid temperature.
I_{max}	Maximum output current. Available for 10 s at start, otherwise as long as allowed by drive temperature. Note: max. motor shaft power is 150% P_{hd} .
S_N	Nominal apparent power.
No-overload use	
$P_{cont.max}$	Typical motor power in no-overload use.
Light-overload use	
I_N	Continuous base current allowing 110% overload for 1 min /5 min.
P_N	Typical motor power in light-overload use.

Heavy-duty use	
I_{hd}	Continuous base current allowing 150% overload for 1 min /5 min.
P_{hd}	Typical motor power in heavy-duty use.
Losses	
P_{loss}	Power loss conducted to coolant.
P_{lossSU}	Power loss of supply module(s).
$P_{lossLCL}$	Power loss of supply LCL filter.
$P_{loss tot}$	Sum of P_{lossSU} and $P_{lossLCL}$.

The current ratings are the same regardless of the supply voltage within one voltage range.

Ratings and dimensions

Dimensions (INU, ISU, DSU)

Frame size	Height mm	Width mm	Depth ¹⁾ mm	Weight kg
D3	975	311	474	140
D4	975	311	474	210
R2i	401	165	193 ¹⁾	9
R3i	466	173	232 ¹⁾	12
R4i	535	240	252 ¹⁾	15
R5i	673	265	276 ¹⁾	23
R7i	880	210	475	85
R8i	880	210	475	127
2xR8i	880	210 ²⁾	475	254
3xR8i	880	210 ²⁾	475	381
4xR8i	880	210 ²⁾	475	508

¹⁾ The depth is without control panels and options.

²⁾ Single module only

Liquid cooling unit

Nominal ratings				Cooling information / Losses			Cooling media		Type designation
P_{max} kW	Internal mass flow at 120 kPa l/min	External mass flow l/min	External pressure loss kPa	P_{loss} kW	$P_{loss\ coolant}$ kW	$P_{loss\ air}$ kW	Internal liquid qty l	External liquid qty l	
Range 380 to 690 V									
70	100	103	125	0.4	0.3	0.1	8	3	ACS800-1007LC-0070
195	300	384	130	0.9	0.7	0.2	28	8	ACS800-1007LC-0195

As standard, liquid-cooling unit includes: industrial cabinet construction, IEC standard compatibility, pipe connections on right hand side with DIN flanges and industrial water heat exchanger.

P_{max}	Maximum nominal cooling power.
Internal massflow	Coolant massflow when cooling circuit is internal.
External massflow	Coolant massflow when cooling circuit uses an external cooling method.
P_{loss}	Power loss conducted to coolant.
$P_{loss\ coolant}$	Power loss conducted to coolant.
$P_{loss\ air}$	Power loss emitted to air (ambient space).

Dimensions

Height mm	Width mm	Depth mm	Weight kg	Type designation
2003	330	644	200	ACS800-1007LC-0070
2003	630	644	400	ACS800-1007LC-0195



Brake options

Brake chopper

The ACS800 series has built-in brake choppers up to frame size R8 (up to 560 kW at 690 V). Above this brake choppers are available as separate brake chopper modules. The brake chopper is part of the standard delivery for the frame sizes R2 and R3 and at 690 V also R4. For the other frames a brake chopper is a selectable option.

Braking control is integrated into the ACS800 series

It controls the braking, supervises the system status and detects failures such as brake resistor and resistor cable short circuits, chopper short circuit, and calculated resistor overtemperature.

$U_N = 230\text{ V}$ (Range 208 to 240 V)

ACS800 type designation	Brake chopper power	Brake resistor(s)			
	Continuous P_{brcont} [kW]	Type designation	R [Ohm]	E_r [kJ]	P_{rcont} [kW]
ACS800-04-0001-2	0.6	SACE08RE44	44	210	1
ACS800-04-0002-2	0.8	SACE08RE44	44	210	1
ACS800-04-0003-2	1.1	SACE08RE44	44	210	1
ACS800-04-0004-2	1.5	SACE08RE44	44	210	1
ACS800-04-0005-2	2.2	SACE15RE22	22	420	2
ACS800-04-0006-2	3	SACE15RE22	22	420	2
ACS800-04-0009-2	4	SACE15RE22	22	420	2
ACS800-04-0011-2	5.5	SACE15RE13	13	435	2
ACS800-04-0016-2	11	SAFUR90F575	8	1800	4.5
ACS800-04-0020-2	17	SAFUR90F575	8	1800	4.5
ACS800-04-0025-2	23	SAFUR80F500	6	2400	6
ACS800-04-0030-2	28	SAFUR125F500	4	3600	9
ACS800-04-0040-2	33	SAFUR125F500	4	3600	9
ACS800-04-0050-2	45	2 x SAFUR125F500	2	7200	18
ACS800-04-0060-2	56	2 x SAFUR125F500	2	7200	18
ACS800-04-0070-2	68	2 x SAFUR125F500	2	7200	18

$U_N = 400\text{ V}$ (Range 380 to 415 V)

ACS800 type designation	Brake chopper power	Brake resistor(s)			
	Continuous P_{brcont} [kW]	Type designation	R [Ohm]	E_r [kJ]	P_{rcont} [kW]
ACS800-04-0003-3	1.1	SACE08RE44	44	210	1
ACS800-04-0004-3	1.5	SACE08RE44	44	210	1
ACS800-04-0005-3	2.2	SACE08RE44	44	210	1
ACS800-04-0006-3	3	SACE08RE44	44	210	1
ACS800-04-0009-3	4	SACE08RE44	44	210	1
ACS800-04-0011-3	5.5	SACE15RE22	22	420	2
ACS800-04-0016-3	7.5	SACE15RE22	22	420	2
ACS800-04-0020-3	11	SACE15RE22	22	420	2
ACS800-04-0023-3	11	SACE15RE22	22	420	2
ACS800-04-0025-3	23	SACE15RE13	13	435	2
ACS800-04-0030-3	28	SACE15RE13	13	435	2
ACS800-04-0035-3	28	SACE15RE13	13	435	2
ACS800-04-0040-3	33	SAFUR90F575	8	1800	4.5
ACS800-04-0050-3	45	SAFUR90F575	8	1800	4.5
ACS800-04-0060-3	56	SAFUR90F575	8	1800	4.5
ACS800-04-0075-3	70	SAFUR80F500	6	2400	6
ACS800-04-0100-3	83	SAFUR125F500	4	3600	9
ACS800-04-0120-3	113	SAFUR125F500	4	3600	9
ACS800-04-0135-3	132	SAFUR200F500	2.7	5400	13.5
ACS800-04-0165-3	132	SAFUR200F500	2.7	5400	13.5
ACS800-04-0205-3	160	SAFUR200F500	2.7	5400	13.5

Brake resistor

The SACE/SAFUR brake resistors are separately available for all ACS800 types. Resistors other than the standard resistors may be used providing the specified resistance value is not decreased, and the heat dissipation capacity of the resistor is sufficient for the drive application.

For ACS800 units, no separate fuses in the brake circuit are required if the following conditions are met:

- The ACS800 mains cable is protected with fuses
- No mains cable/fuse overrating takes place

ACS800 type designation	Brake chopper power				Brake resistor(s)			
	5/60 s P_{br5} [kW]	10/60 s P_{br10} [kW]	30/60 s P_{br30} [kW]	Continuous P_{brcont} [kW]	Type designation	R [Ohm]	E_r [kJ]	P_{rcont} [kW]
ACS800-04(M)-0080-2	68	68	68	54	SAFUR 160F380	1.78	3600	9
ACS800-04(M)-0100-2	83	83	83	54	SAFUR 160F380	1.78	3600	9
ACS800-04(M)-0120-2	105	67	60	40	2xSAFUR200F500	1.35	10800	27
ACS800-04(M)-0140-2	135	135	135	84	2xSAFUR160F380	0.89	7200	18
ACS800-04(M)-0170-2	135	135	135	84	2xSAFUR160F380	0.89	7200	18
ACS800-04(M)-0210-2	165	165	165	98	2xSAFUR160F380	0.89	7200	18
ACS800-04(M)-0230-2	165	165	165	113	2xSAFUR160F380	0.89	7200	18
ACS800-04(M)-0260-2	223	170	125	64	4xSAFUR160F380	0.45	14400	36
ACS800-04(M)-0300-2	223	170	125	64	4xSAFUR160F380	0.45	14400	36

ACS800 type designation	Brake chopper power				Brake resistor(s)			
	5/60 s P_{br5} [kW]	10/60 s P_{br10} [kW]	30/60 s P_{br30} [kW]	Continuous P_{brcont} [kW]	Type designation	R [Ohm]	E_r [kJ]	P_{rcont} [kW]
ACS800-04(M)-0140-3	135	135	100	80	SAFUR200F500	2.70	5400	13.5
ACS800-04(M)-0170-3	165	150	100	80	SAFUR200F500	2.70	5400	13.5
ACS800-04(M)-0210-3	165	150	100	80	SAFUR200F500	2.70	5400	13.5
ACS800-04(M)-0260-3	240	240	240	173	2xSAFUR210F575	1.70	8400	21
ACS800-04(M)-0320-3	300	300	300	143	2xSAFUR200F500	1.35	10800	27
ACS800-04(M)-0400-3	375	375	273	130	4xSAFUR125F500	1.00	14400	36
ACS800-04(M)-0440-3	473	355	237	120	4xSAFUR210F575	0.85	16800	42
ACS800-04(M)-0490-3	500	355	237	120	4xSAFUR210F575	0.85	16800	42

Brake options

$U_N = 500 \text{ V}$ (Range 380 to 500 V)

ACS800 type designation	Brake chopper power Continuous P_{brcont} [kW]	Brake resistor(s)			
		Type designation	R [Ohm]	E_r [kJ]	P_{rcont} [kW]
ACS800-04-0004-5	1.5	SACE08RE44	44	210	1
ACS800-04-0005-5	2.2	SACE08RE44	44	210	1
ACS800-04-0006-5	3	SACE08RE44	44	210	1
ACS800-04-0009-5	4	SACE08RE44	44	210	1
ACS800-04-0011-5	5.5	SACE08RE44	44	210	1
ACS800-04-0016-5	7.5	SACE15RE22	22	420	2
ACS800-04-0020-5	11	SACE15RE22	22	420	2
ACS800-04-0025-5	15	SACE15RE22	22	420	2
ACS800-04-0028-5	15	SACE15RE22	22	420	2
ACS800-04-0030-5	28	SACE15RE13	13	435	2
ACS800-04-0040-5	33	SACE15RE13	13	435	2
ACS800-04-0045-5	33	SACE15RE13	13	435	2
ACS800-04-0105-5	83	SAFUR80F500	6	2400	6
ACS800-04-0050-5	45	SAFUR90F575	8	1800	4.5
ACS800-04-0060-5	56	SAFUR90F575	8	1800	4.5
ACS800-04-0070-5	68	SAFUR90F575	8	1800	4.5
ACS800-04-0105-5	83	SAFUR80F500	6	2400	6
ACS800-04-0120-5	113	SAFUR125F500	4	3600	9
ACS800-04-0140-5	135	SAFUR125F500	4	3600	9
ACS800-04-0165-5	160	SAFUR125F500	4	3600	9
ACS800-04-0205-5	160	SAFUR125F500	4	3600	9
ACS800-04-0255-5	200	SAFUR200F500	2.7	5400	13.5

ACS800 type designation	Brake chopper power				Brake resistor(s)			
	P_{br5} [kW]	P_{br10} [kW]	P_{br30} [kW]	Continuous P_{brcont} [kW]	Type designation	R [Ohm]	E_r [kJ]	P_{rcont} [kW]
ACS800-04(M)-0170-5	165	132 ²⁾	120	80	SAFUR200F500	2.70	5400	13.5
ACS800-04(M)-0210-5	198	132 ²⁾	120	80	SAFUR200F500	2.70	5400	13.5
ACS800-04(M)-0260-5	198 ¹⁾	132 ²⁾	120	80	SAFUR200F500	2.70	5400	13.5
ACS800-04(M)-0320-5	300	300	300	300	2xSAFUR125F500	2.00	7200	18
ACS800-04(M)-0400-5	375	375	375	234	2xSAFUR210F575	1.70	8400	21
ACS800-04(M)-0440-5	473	473	450	195	2xSAFUR200F500	1.35	10800	27
ACS800-04(M)-0490-5	480	480	470	210	2xSAFUR200F500	1.35	10800	27
ACS800-04(M)-0550-5	600	400 ⁴⁾	300	170	4xSAFUR125F500	1.00	14400	36
ACS800-04(M)-0610-5	600 ³⁾	400 ⁴⁾	300	170	4xSAFUR125F500	1.00	14400	36

$U_N = 690 \text{ V}$ (Range 525 to 690 V)

ACS800 type designation	Brake chopper power Continuous P_{brcont} [kW]	Brake resistor(s)			
		Type designation	R [Ohm]	E_r [kJ]	P_{rcont} [kW]
ACS800-04-0011-7	8	SACE08RE44	44	210	1
ACS800-04-0016-7	11	SACE08RE44	44	210	1
ACS800-04-0020-7	16	SACE08RE44	44	210	1
ACS800-04-0025-7	22	SACE15RE44	44	210	1
ACS800-04-0030-7	28	SACE15RE22	22	420	2
ACS800-04-0040-7	22/33 ⁸⁾	SACE15RE22	22	420	2
ACS800-04-0050-7	45	SACE15RE13	13	435	2
ACS800-04-0060-7	56	SACE15RE13	13	435	2
ACS800-04-0070-7	68	SAFUR90F575	8	1800	4.5
ACS800-04-0100-7	83	SAFUR90F575	8	1800	4.5
ACS800-04-0120-7	113	SAFUR90F575	6	2400	6
ACS800-04-0145-7	160	SAFUR80F500	6	2400	6
ACS800-04-0175-7	160	SAFUR80F500	6	2400	6
ACS800-04-0205-7	160	SAFUR80F500	6	2400	6

ACS800 type designation	Brake chopper power				Brake resistor(s)			
	P_{br5} [kW]	P_{br10} [kW]	P_{br30} [kW]	Continuous P_{brcont} [kW]	Type designation	R [Ohm]	E_r [kJ]	P_{rcont} [kW]
ACS800-04(M)-0140-7	125 ⁵⁾	110	90	75	SAFUR80F500	6.00	2400	6
ACS800-04(M)-0170-7	125 ⁶⁾	110	90	75	SAFUR80F500	6.00	2400	6
ACS800-04(M)-0210-7	125 ⁶⁾	110	90	75	SAFUR80F500	6.00	2400	6
ACS800-04(M)-0260-7	135 ⁷⁾	120	100	80	SAFUR80F500	6.00	2400	6
ACS800-04(M)-0320-7	300	300	300	260	SAFUR200F500	2.70	5400	13.5
ACS800-04(M)-0400-7	375	375	375	375	SAFUR200F500	2.70	5400	13.5
ACS800-04(M)-0440-7	430	430	430	385	SAFUR200F500	2.70	5400	13.5
ACS800-04(M)-0490-7	550	400	315	225	2xSAFUR125F500	2.00	7200	18
ACS800-04(M)-0550-7	550	400	315	225	2xSAFUR125F500	2.00	7200	18
ACS800-04(M)-0610-7	550	400	315	225	2xSAFUR125F500	2.00	7200	18

Maximum braking power of the ACS800 equipped with the standard chopper and the standard resistor.

P_{br5} 5 s / 1 min

P_{br10} 10 s / 1 min

P_{br30} 30 s / 1 min

The drive and the chopper will withstand this braking power for 5/10/30 seconds every one minute. Note: The braking energy transmitted to the resistor during any period shorter than 400 seconds may not exceed E_r . (E_r varies depending on the resistor).

P_{brcont} Continuous brake chopper power. The value applies to the minimum resistance value. With a higher resistance value the P_{brcont} may increase in some ACS800-02/07 units.

R Resistance value for the listed resistor type. Note: This is also the minimum allowable resistance value for the brake resistor.

E_r Energy pulse that the resistor assembly will withstand (400 s duty cycle). This energy will heat the resistor element from 40 °C to the maximum allowable temperature.

P_{rcont} Continuous power (heat) dissipation of the resistor when placed correctly. Energy E_r dissipates in 400 seconds.

¹⁾ 240 kW possible if ambient below 33 °C.

²⁾ 160 kW possible if ambient below 33 °C.

³⁾ 630 kW possible if ambient below 33 °C.

⁴⁾ 450 kW possible if ambient below 33 °C.

⁵⁾ 135 kW possible if ambient below 33 °C.

⁶⁾ 148 kW possible if ambient below 33 °C.

⁷⁾ 160 kW possible if ambient below 33 °C.

⁸⁾ 22 kW with standard 22 ohm resistor, 33 kW with 32 to 37 ohm resistor.

All brake resistors are to be installed outside the converter module.

The SACE brake resistors are built-in an IP21 metal housing.

The SAFUR brake resistors are built-in an IP00 metal frame.

Brake resistor type designation	Height mm	Width mm	Depth mm	Weight kg
SACE08RE44	365	290	131	6.1
SACE15RE22	365	290	131	6.1
SACE15RE13	365	290	131	6.8
SAFUR80F500	600	300	345	14
SAFUR90F575	600	300	345	12
SAFUR160F380	1320	300	345	25
SAFUR180F460	1320	300	345	32
SAFUR125F500	1320	300	345	25
SAFUR200F500	1320	300	345	30
SAFUR210F575	1320	300	345	27



SACE 15 RE 13

Brake options

Brake chopper and resistor options for ACS800-04 in frame sizes 2xR8i

Type designation	Nominal ratings					Duty cycle (1 min / 5 min)		Duty cycle (10 s / 60 s)		E_r kJ	Brake chopper type	Resistor type
	$P_{br, max}$ kW	R ohm	I_{max} A	I_{rms} A	$P_{cont.}$ kW	$P_{br.}$ kW	I_{rms} A	$P_{br.}$ kW	I_{rms} A			
$U_N = 400\text{ V}$ (Range 380 to 415 V)												
ACS800-04-0610-3	706	2x1.2	1090	298	192	606	936	706	1090	-	2xNBRA659	-
ACS800-04-0770-3	706	2x1.2	1090	298	192	606	936	706	1090	-	2xNBRA659	-
ACS800-04-0870-3	1058	3x1.2	1635	447	288	909	1404	1059	1635	-	3xNBRA659	-
ACS800-04-1030-3	1058	3x1.2	1635	447	288	909	1404	1059	1635	-	3xNBRA659	-
ACS800-04-0610-3	706	2x1.2	1090	168	108	333	514	575	888	24000	2xNBRA659	2x(2xSAFUR180F460)
ACS800-04-0770-3	706	2x1.2	1090	168	108	333	514	575	888	24000	2xNBRA659	2x(2xSAFUR180F460)
ACS800-04-0870-3	1058	3x1.2	1635	252	162	500	771	862	1332	36000	3xNBRA659	3x(2xSAFUR180F460)
ACS800-04-1030-3	1058	3x1.2	1635	252	162	500	771	862	1332	36000	3xNBRA659	3x(2xSAFUR180F460)
$U_N = 500\text{ V}$ (Range 380 to 500 V)												
ACS800-04-0760-5	806	2x1.43	1142	272	218	634	782	806	996	-	2xNBRA659	-
ACS800-04-0910-5	806	2x1.43	1142	272	218	634	782	806	996	-	2xNBRA659	-
ACS800-04-1090-5	1208	3x1.43	1713	408	327	951	1173	1209	1494	-	3xNBRA659	-
ACS800-04-1210-5	1208	3x1.43	1713	408	327	951	1173	1209	1494	-	3xNBRA659	-
ACS800-04-0760-5	806	2x1.35	1210	134	108	333	412	575	710	21600	2xNBRA659	2x(2xSAFUR200F500)
ACS800-04-0910-5	806	2x1.35	1210	134	108	333	412	575	710	21600	2xNBRA659	2x(2xSAFUR200F500)
ACS800-04-1090-5	1208	3x1.35	1815	201	162	500	618	862	1065	32400	3xNBRA659	3x(2xSAFUR200F500)
ACS800-04-1210-5	1208	3x1.35	1815	201	162	500	618	862	1065	32400	3xNBRA659	3x(2xSAFUR200F500)
$U_N = 690\text{ V}$ (Range 525 to 690 V)												
ACS800-04-0750-7	807	2x2.72	828	214	238	596	534	808	722	-	2xNBRA669	-
ACS800-04-0870-7	807	2x2.72	828	214	238	596	534	808	722	-	2xNBRA669	-
ACS800-04-1060-7	1211	3x2.72	1242	321	357	894	801	1212	1083	-	3xNBRA669	-
ACS800-04-1160-7	1211	3x2.72	1242	321	357	894	801	1212	1083	-	3xNBRA669	-
ACS800-04-0750-7	807	2x1.35	1670	194	108	333	298	575	514	21600	2xNBRA669	2x(2xSAFUR200F500)
ACS800-04-0870-7	807	2x1.35	1670	194	108	333	298	575	514	21600	2xNBRA669	2x(2xSAFUR200F500)
ACS800-04-1060-7	1211	3x1.35	2505	291	162	500	447	862	771	32400	3xNBRA669	3x(2xSAFUR200F500)
ACS800-04-1160-7	1211	3x1.35	2505	291	162	500	447	862	771	32400	3xNBRA669	3x(2xSAFUR200F500)

Dimensions

Frame size	Height mm	Width mm	Depth mm	Weight kg
NBRA659	584	334	240	26
NBRA669	584	334 ¹⁾	240	26 ¹⁾
SAFUR180F460	1320	300 ¹⁾	345	32 ¹⁾
SAFUR125F500	1320	300 ¹⁾	345	25 ¹⁾
SAFUR200F500	1320	300 ¹⁾	345	30 ¹⁾
SAFUR210F575	1320	300 ¹⁾	345	27 ¹⁾

¹⁾ Single drive module only.

$P_{br, max}$	Maximum braking power of the NBRA-6xx chopper and SAFUR resistor combination. The chopper will withstand this braking power for one minute every ten minutes.
P_{br}	Maximum braking power of the drive with the specified resistor(s). The drive and the chopper will withstand this braking power for a period of time indicated by the duty cycle.
E_r	Short energy pulse that the resistor assembly withstands every 400 seconds.

This energy will heat the resistor element from 40 °C (104 °F) to the maximum allowable temperature.

Note: The braking energy transmitted to the resistor during any period shorter than 400 seconds may not exceed E_r .

The standard resistor therefore withstands continuous braking of $P_{br, max}$ typically 20 to 40 seconds ($t = E_r / P_{br, max}$).

R	Recommended brake resistor resistance. Also nominal resistance of corresponding SAFUR resistor.
I_{max}	Maximum peak current per chopper during braking. Current is achieved with minimum resistor resistance.
I_{rms}	Corresponding rms current per chopper during load cycle.

Heat loss of brake chopper is 1% of braking power.
Heat loss of section with brake resistors is the same as braking power.

Brake options

3-phase high power brake units

Resistors values		Ratings R_{min}								Ratings R_{max}								Type designation	Frame size
R_{min}	R_{max}	No-overload use				Cycle load (1 min/5 min)				No-overload use				Cycle load (1 min/5 min)					
Ohm	Ohm	I_{dc}	I_{rms}	$P_{contmax}$	I_{max}	I_{dc}	$I_{rms-R_{min}}$	$P_{br-R_{min}}$	I_{dc}	I_{rms}	$P_{contmax}$	I_{max}	I_{dc}	$I_{rms-R_{max}}$	$P_{br-R_{max}}$				
		A DC	A DC	kW	A DC	A DC	A DC	kW	A DC	A DC	kW	A DC	A DC	A DC	kW				
$U_N = 400\text{ V}$ (Range 380 to 415 V)																			
3.5	4.1	390	155	250	185	500	176	320	390	143	250	156	422	148	270	ACS800-604-0250-3	R7i		
1.7	2.1	781	310	500	370	999	351	640	781	282	500	312	827	291	530	ACS800-604-0500-3	R8i		
1.2	1.4	1171	465	750	555	1499	527	960	1171	424	750	468	1241	436	800	ACS800-604-0750-3	R8i		
1.7	2.1	1562	621	1000	740	1998	702	1290	1562	565	1000	625	1655	581	1060	ACS800-604-1000-3	2xR8i		
1.2	1.4	2342	931	1510	1110	2997	1053	1930	2342	847	1510	937	2482	872	1600	ACS800-604-1510-3	2xR8i		
1.2	1.4	3514	1396	2260	1665	4496	1580	2890	3514	1271	2260	1405	3723	1308	2400	ACS800-604-2260-3	3xR8i		
1.2	1.4	4685	1862	3010	2220	5994	2106	3860	4685	1694	3010	1874	4964	1744	3190	ACS800-604-3010-3	4xR8i		
1.2	1.4	5856	2327	3770	2775	7493	2633	4820	5856	2118	3770	2342	6205	2180	3990	ACS800-604-3770-3	5xR8i		
$U_N = 500\text{ V}$ (Range 380 to 500 V)																			
4.3	5.2	390	155	310	185	500	176	400	390	143	310	156	422	148	340	ACS800-604-0310-5	R7i		
2.2	2.6	781	310	630	370	999	351	800	781	284	630	312	835	293	670	ACS800-604-0630-5	R8i		
1.4	1.7	1171	465	940	555	1499	527	1210	1171	430	940	468	1277	449	1030	ACS800-604-0940-5	R8i		
2.2	2.6	1562	621	1260	740	1998	702	1610	1562	568	1260	625	1671	587	1340	ACS800-604-1260-5	2xR8i		
1.4	1.7	2342	931	1880	1110	2997	1053	2410	2342	860	1880	937	2555	898	2060	ACS800-604-1880-5	2xR8i		
1.4	1.7	3514	1396	2830	1665	4496	1580	3620	3514	1289	2830	1405	3832	1347	3080	ACS800-604-2830-5	3xR8i		
1.4	1.7	4685	1862	3770	2220	5994	2106	4820	4685	1719	3770	1874	5110	1795	4110	ACS800-604-3770-5	4xR8i		
1.4	1.7	5856	2327	4710	2775	7493	2633	6030	5856	2149	4710	2342	6387	2244	5140	ACS800-604-4710-5	5xR8i		
$U_N = 690\text{ V}$ (Range 525 to 690 V)																			
6.0	7.1	390	155	430	185	500	176	550	390	143	430	156	422	148	470	ACS800-604-0430-7	R7i		
3.0	3.6	781	310	870	370	999	351	1110	781	283	870	312	833	293	920	ACS800-604-0870-7	R8i		
2.0	2.4	1171	465	1300	555	1499	527	1660	1171	425	1300	468	1249	439	1390	ACS800-604-1300-7	R8i		
3.0	3.6	1562	621	1730	740	1998	702	2220	1562	567	1730	625	1665	585	1850	ACS800-604-1730-7	2xR8i		
2.0	2.4	2342	931	2600	1110	2997	1053	3330	2342	850	2600	937	2498	878	2770	ACS800-604-2600-7	2xR8i		
2.0	2.4	3514	1396	3900	1665	4496	1580	4990	3514	1275	3900	1405	3746	1316	4160	ACS800-604-3900-7	3xR8i		
2.0	2.4	4685	1862	5200	2220	5994	2106	6650	4685	1700	5200	1874	4995	1755	5540	ACS800-604-5200-7	4xR8i		
2.0	2.4	5856	2327	6500	2775	7493	2633	8320	5856	2125	6500	2342	6244	2194	6930	ACS800-604-6500-7	5xR8i		

Dimensions

Frame size	Height mm	Width mm	Depth mm	Weight kg	Noise level dB(A)	Air flow m ³ /h
R2i	401	165	193 ³⁾	9	62	35
R3i	466	173	232 ³⁾	12	62	69
R4i	525	240	252 ³⁾	15	62	103
R5i	673	265	276 ³⁾	23	65	168
R7i ¹⁾	963	170	404	37	64	800
R8i	1397	235	596	130	72z	1280
2xR8i	1397	245 ²⁾	596	260	74	2560
3xR8i	1397	245 ²⁾	596	390	76	3840
4xR8i	1397	245 ²⁾	596	520	76	5120
5xR8i	1397	245 ²⁾	596	650	77	6400

¹⁾ Dimensions do not include cooling fan.

²⁾ Single module only.

³⁾ The depth is without control panels and options.

Resistor	
R_{min}	Minimum allowed resistance value of the brake resistor for one phase of the brake module.
R_{max}	Resistance value of the brake resistor for one phase of the brake module corresponding to the maximum achieved continuous braking power.
Note: Connect one resistor per brake module phase. For example, a brake unit of frame size 2xR8i including two brake modules → 2 x 3 resistors are needed.	
Typical ratings: No-overload use	
I_{dc}	Total input DC current of brake unit.
I_{rms}	Total rms DC output phase current of brake unit.
I_{max}	Peak brake current (DC) per chopper module phase.
$P_{cont,max}$	Maximum continuous braking power per brake unit.
Cyclic load (1 min / 5 min)	
I_{dc}	Total input DC current of brake unit during a period of 1 minute with braking power P_{br} .
I_{rms}	Total rms DC current per brake unit phase during a period of 1 minute with braking power P_{br} .
P_{br}	Short term braking power per brake unit allowed for 1 minute every 5 minutes.

Brake options

Multidrive module brake units

Brake unit type designation	Nominal ratings					Duty cycle (1 min / 5 min)		Duty cycle (10 s / 60 s)		Noise level dB(A)	Air flow m³/h	Resistor type designation
	$P_{br. max}$ kW	R ohm	I_{max} A	I_{rms} A	$P_{cont.}$ kW	$P_{br.}$ kW	I_{rms} A	$P_{br.}$ kW	I_{rms} A			
$U_N = 400 V$ (Range 380 to 415 V)												
Only the chopper												
Chopper-0210-3 (NBRA658)	230	1.7	384	109	70	230	355	230	355	64	660	-
Chopper-0320-3 (NBRA659)	353	1.2	545	149	96	303	468	353	545	64	660	-
Chopper-0640-3 (2xNBRA659)	706	0.6	1090	298	192	606	936	706	1090	67	1320	-
Chopper-0960-3 (3xNBRA659)	1058	0.4	1635	447	288	909	1404	1059	1635	68	1980	-
Chopper-1280-3 (4xNBRA659)	1411	0.3	2180	596	384	1212	1872	1412	2180	69	2640	-
Chopper-1600-3 (5xNBRA659)	1764	0.24	2725	745	480	1515	2340	1765	2725	70	3300	-
Chopper-1920-3 (6xNBRA659)	2117	0.2	3270	894	576	1818	2808	2118	3270	71	3960	-
Chopper with the resistor												
Chopper-0210-3 (NBRA658)	230	1.7	384	65	42	130	200	224	346	66	2500	2 x SAFUR210F575
Chopper-0320-3 (NBRA659)	353	1.2	545	84	54	167	257	287	444	66	2500	2 x SAFUR180F460
Chopper-0640-3 (2xNBRA659)	706	0.6	1090	168	108	333	514	575	888	69	5000	2 x (2 x SAFUR180F460)
Chopper-0960-3 (3xNBRA659)	1058	0.4	1635	252	162	500	771	862	1332	70	7500	3 x (2 x SAFUR180F460)
Chopper-1280-3 (4xNBRA659)	1411	0.3	2180	336	216	667	1028	1150	1776	71	10000	4 x (2 x SAFUR180F460)
Chopper-1600-3 (5xNBRA659)	1764	0.24	2725	420	270	833	1285	1437	2220	72	12500	5 x (2 x SAFUR180F460)
Chopper-1920-3 (6xNBRA659)	2117	0.2	3270	504	324	1000	1542	1724	2664	73	15000	6 x (2 x SAFUR180F460)
$U_N = 500 V$ (Range 380 to 500 V)												
Only the chopper												
Chopper-0260-5 (NBRA658)	268	2.15	380	101	81	268	331	268	331	64	660	-
Chopper-0400-5 (NBRA659)	403	1.43	571	136	109	317	391	403	498	64	660	-
Chopper-0800-5 (2xNBRA659)	806	0.72	1142	272	218	634	782	806	996	67	1320	-
Chopper-1200-5 (3xNBRA659)	1208	0.48	1713	408	327	951	1173	1209	1494	68	1980	-
Chopper-1600-5 (4xNBRA659)	1611	0.36	2284	544	436	1268	1564	1612	1992	69	2640	-
Chopper-2000-5 (5xNBRA659)	2014	0.29	2855	680	545	1585	1955	2015	2490	70	3300	-
Chopper-2400-5 (6xNBRA659)	2417	0.24	3426	816	654	1902	2346	2418	2988	71	3960	-
Chopper with the resistor												
Chopper-0260-5 (NBRA658)	268	2.00	408	45	36	111	137	192	237	66	2500	2 x SAFUR125F500
Chopper-0400-5 (NBRA659)	403	1.35	605	67	54	167	206	287	355	66	2500	2 x SAFUR200F500
Chopper-0800-5 (2xNBRA659)	806	0.68	1210	134	108	333	412	575	710	69	5000	2 x (2 x SAFUR200F500)
Chopper-1200-5 (3xNBRA659)	1208	0.45	1815	201	162	500	618	862	1065	70	7500	3 x (2 x SAFUR200F500)
Chopper-1600-5 (4xNBRA659)	1611	0.34	2420	268	216	667	824	1150	1420	71	10000	4 x (2 x SAFUR200F500)
Chopper-2000-5 (5xNBRA659)	2014	0.27	3025	335	270	833	1030	1437	1775	72	12500	5 x (2 x SAFUR200F500)
Chopper-2400-5 (6xNBRA659)	2417	0.23	3630	402	324	1000	1236	1724	2130	73	15000	6 x (2 x SAFUR200F500)
$U_N = 690 V$ (Range 525 to 690 V)												
Only the chopper												
Chopper-0400-6 (NBRA 669)	404	2.72	414	107	119	298	267	404	361	64	660	-
Chopper-0800-6 (2xNBRA669)	807	1.36	828	214	238	596	534	808	722	67	660	-
Chopper-1200-6 (3xNBRA669)	1211	0.91	1242	321	357	894	801	1212	1083	68	1320	-
Chopper-1600-6 (4xNBRA669)	1615	0.68	1656	428	476	1192	1068	1616	1444	69	1980	-
Chopper-2000-6 (5xNBRA669)	2019	0.54	2070	535	595	1490	1335	2020	1805	70	2640	-
Chopper-2400-6 (6xNBRA669)	2422	0.45	2484	642	714	1788	1602	2424	2166	71	3300	-
Chopper with the resistor												
Chopper-0400-6 (NBRA 669)	404	1.35	835	97	54	167	149	287	257	66	2500	2 x SAFUR200F500
Chopper-0800-6 (2xNBRA669)	807	0.68	1670	194	108	333	298	575	514	69	5000	2 x (2 x SAFUR200F500)
Chopper-1200-6 (3xNBRA669)	1211	0.45	2505	291	162	500	447	862	771	70	7500	3 x (2 x SAFUR200F500)
Chopper-1600-6 (4xNBRA669)	1615	0.34	3340	388	216	667	596	1150	1028	71	10000	4 x (2 x SAFUR200F500)
Chopper-2000-6 (5xNBRA669)	2019	0.27	4175	485	270	833	745	1437	1285	72	12500	5 x (2 x SAFUR200F500)
Chopper-2400-6 (6xNBRA669)	2422	0.23	5010	582	324	2000	894	1724	1542	73	15000	6 x (2 x SAFUR200F500)

Dimensions

Frame size	Height mm	Width mm	Depth mm	Weight kg
NBRA658	584	334	240	26
NBRA659	584	334 ¹⁾	240	26 ¹⁾
NBRA669	584	334 ¹⁾	240	26 ¹⁾
SAFUR180F460	1320	300 ¹⁾	345	32 ¹⁾
SAFUR125F500	1320	300 ¹⁾	345	25 ¹⁾
SAFUR200F500	1320	300 ¹⁾	345	30 ¹⁾
SAFUR210F575	1320	300 ¹⁾	345	27 ¹⁾

¹⁾ Single drive module only.

Brake options

Liquid cooled 3-phase high power brake modules

Resistor data		Nominal ratings		No-overload use	Cycle load (1 min/5 min)			Losses ¹⁾	Noise level	Mass flow	Type designation	Frame size INU
R_{min} Ohm	R_{max} Ohm	I_{dc} A DC	I_{rms} A DC	$P_{cont. max}$ kW	I_{dc} A DC	I_{rms} A DC	P_{br} kW	P_{loss} kW	dB(A)	l/min		
$U_N = 400\text{ V}$ (Range 380 to 415 V)												
3 x 3,5	3 x 4,1	390	155	250	500	176	320	2.5	62	13	ACS800-604LC-0250-3	R7i
3 x 1,7	3 x 2,1	781	310	500	999	351	640	5.0	62	13	ACS800-604LC-0500-3	R8i
3 x 1,2	3 x 1,4	1171	465	750	1499	527	960	7.5	62	13	ACS800-604LC-0750-3	R8i
2 x (3 x 1,7)	2 x (3 x 2,1)	1562	621	1000	1998	702	1290	10.0	64	26	ACS800-604LC-1000-3	2xR8i
2 x (3 x 1,2)	2 x (3 x 1,4)	2342	931	1510	2997	1053	1930	15.1	64	26	ACS800-604LC-1510-3	2xR8i
3 x (3 x 1,2)	3 x (3 x 1,4)	3514	1396	2260	4496	1580	2890	22.6	66	39	ACS800-604LC-2260-3	3xR8i
4 x (3 x 1,2)	4 x (3 x 1,4)	4685	1862	3010	5994	2106	3860	30.1	67	52	ACS800-604LC-3010-3	4xR8i
$U_N = 500\text{ V}$ (Range 380 to 500 V)												
3 x 4,3	3 x 5,2	390	155	310	500	176	400	2.5	62	13	ACS800-604LC-0310-5	R7i
3 x 2,2	3 x 2,6	781	310	630	999	351	800	5.0	62	13	ACS800-604LC-0630-5	R8i
3 x 1,4	3 x 1,7	1171	465	940	1499	527	1210	7.5	62	13	ACS800-604LC-0940-5	R8i
2 x (3 x 2,2)	2 x (3 x 2,6)	1562	621	1260	1998	702	1610	10.0	64	26	ACS800-604LC-1260-5	2xR8i
2 x (3 x 1,4)	2 x (3 x 1,7)	2342	931	1880	2997	1053	2410	15.1	64	26	ACS800-604LC-1880-5	2xR8i
3 x (3 x 1,4)	3 x (3 x 1,7)	3514	1396	2830	4496	1580	3620	22.6	66	39	ACS800-604LC-2830-5	3xR8i
4 x (3 x 1,4)	4 x (3 x 1,7)	4685	1862	3770	5994	2106	4820	30.1	67	52	ACS800-604LC-3770-5	4xR8i
$U_N = 690\text{ V}$ (Range 525 to 690 V)												
3 x 6	3 x 7,1	390	155	430	500	176	550	2.8	62	13	ACS800-604LC-0430-7	R7i
3 x 3	3 x 3,6	781	310	870	999	351	1110	5.7	62	13	ACS800-604LC-0870-7	R8i
3 x 2	3 x 2,4	1171	465	1300	1499	527	1660	8.5	62	13	ACS800-604LC-1300-7	R8i
2 x (3 x 3)	2 x (3 x 3,6)	1562	621	1730	1998	702	2220	11.3	64	26	ACS800-604LC-1730-7	2xR8i
2 x (3 x 2)	2 x (3 x 2,4)	2342	931	2600	2997	1053	3330	17.0	64	26	ACS800-604LC-2600-7	2xR8i
3 x (3 x 2)	3 x (3 x 2,4)	3514	1396	3900	4496	1580	4990	25.4	66	39	ACS800-604LC-3900-7	3xR8i
4 x (3 x 2)	4 x (3 x 2,4)	4685	1862	5200	5994	2106	6650	33.9	67	52	ACS800-604LC-5200-7	4xR8i

Dimensions

Frame size	Height ¹⁾ mm	Width ²⁾ mm	Depth mm	Weight kg
R7i	2003	400/700	644	300
R8i	2003	400/700	644	300
2xR8i	2003	800/1400	644	600
3xR8i	2003	1200/2100	644	900
4xR8i	2003	1600/2800	644	1200

¹⁾ Pressure release lids require an additional 400 mm.

²⁾ First values for bottom exit and latter values for top exit.

Resistor	
R_{min}	Minimum allowed resistance value of the brake resistor for one phase of the brake module.
R_{max}	Resistance value of the brake resistor for one phase of the brake module corresponding to the maximum achieved continuous braking power.
Nominal ratings	
I_{dc}	Total input DC current of brake unit.
I_{rms}	Total rms DC output phase current of brake unit.
No-overload use	
$P_{cont. max}$	Typical motor power in no-overload use.
Cyclic load	
I_{dc}	Total input DC current of brake unit during a period of 1 minute with braking power P_{br} .
I_{rms}	Corresponding RMS current per chopper during load cycle.
P_{br}	Short term braking power per brake unit allowed for 1 minute every 5 minutes.
Losses	
P_{loss}	Power loss conducted to coolant.

EMC filters

EMC - Electromagnetic Compatibility and modules

The electrical/electronic equipment must be able to operate without problems within an electromagnetic environment. This is called immunity. The ACS800 is designed to have adequate immunity against interference from other equipment. Likewise, the equipment must not disturb or interfere with any other product or system within its locality. This is called emission. Each ACS800 model can be equipped with a built-in filter to reduce high frequency emission.

EMC standards

The EMC product standard (EN 61800-3 + Amendment A11(2000)) covers the specific EMC requirements stated for drives (tested with motor and cable) within the EU.

EMC standards such as EN 55011, or EN 61000-6-3/4, apply to industrial and household equipments and systems including drive component inside. Drive units complying with requirements of EN 61800-3 are always compliant with comparable categories in EN 55011 and EN 61000-6-3/4, but not necessarily vice versa. EN 55011 and EN 61000-6-3/4 do not specify cable length nor require a motor to be connected as a load. The emission limits are comparable according to the following table, EMC standards.

EMC standards

EN61800-3:2004 product standard	EN 55011, product family standard for industrial, scientific and medical (ISM) equipment	EN61000-6-4, generic emission standard for industrial environments	EN61000-6-3, generic emission standard for residential, commercial and light-industrial environment
Category C1 (1 st environment)	Group 1 Class B	Not applicable	Applicable
Category C2 (1 st environment)	Group 1 Class A	Applicable	Not applicable
Category C3 (2 nd environment)	Group 2 Class A	Not applicable	Not applicable
Category C4 (2 nd environment)	Not applicable	Not applicable	Not applicable

1st environment vs 2nd environment

1st environment (category C1 and C2)

"1st environment includes domestic premises. It also includes establishments directly connected without intermediate transformer to a low-voltage power supply network which supplies buildings used for domestic purposes.

2nd environment (category C3 and C4)

"2nd environment includes all establishments other than those directly connected to a low-voltage power supply network which supplies buildings used for domestic purposes."

Selecting an EMC filter

The following table gives the correct filter selection.

Type designation	Voltage	Frame sizes	1 st environment, restricted distribution, C2, grounded network (TN)	2 nd environment, C3, grounded network (TN)	2 nd environment, C3, floating network (IT)
ACS800-04	400-500	R2-R6	+E202	+E200/+E210 (R6 frame size)	- *)/+E210 (R6 frame size)
	690	R2-R6	-	+E200/+E210 (R6 frame size)	- *)/+E210 (R6 frame size)
ACS800-04(M)	400-500	R7-R8	+E202 ¹⁾	+E210	+E210
	690	R7-R8	-	+E210	+E210
ACS800-04	400-500	R7-R8	-	+E210	+E210
	690	R7-R8	-	+E210	+E210

¹⁾ Includes externally mounted components.

*) These drives are category C4 equipment and EMC plan for installation is required.

Sine filters

ABB sine filter solution

The ACS800 sine filter solution is an ACS800 industrial drive equipped with a sine filter. It enjoys most of the premium features of the standard ACS800 industrial drive. The LC filter suppresses the high frequency components of the output voltage.

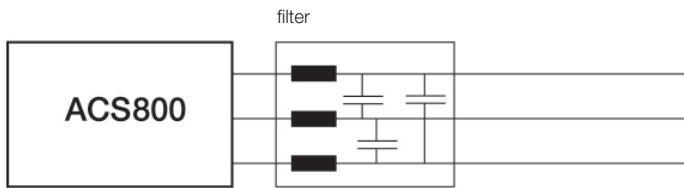

This means that the output voltage waveform is almost sinusoidal without high voltage peaks.

Filters are available in IP00 degree of protection over the whole power range. Up to ACS800-04 frame size R6 power range, filters are available also with IP23 enclosure class.

The ABB sine filter solution can be used in a variety of applications:

- Motor does not have adequate insulation for VSD duty
- Total motor cable length is long e.g. there are a number of parallel motors
- Step up applications e.g. medium voltage motor needs to be driven
- Step down applications
- There are industry specific requirements for peak voltage level and voltage rise time
- Motor noise needs to be reduced
- Maximum safety and reliability is needed in e.g. EX applications
- Submersible pumps with long motor cables e.g. in the oil industry

Main features

- Optimized LC design that takes into account switching frequency, voltage drop and filtering characteristics
- Proven technology as ABB has delivered hundreds of sine filter solutions over the last 20 years
- Cost effective solution
- Standard software has all the parameters that need to be set

Feature	Benefit	Note
Sinusoidal output voltage	No additional stress on the motor insulation: non-VSD compliant motors can be used, motor reliability and lifetime are maximized.	
	Allows the use of transformers in the drive output to match any required motor voltage.	Voltage drop at motor cable can be compensated with transformer i.e. there are no restrictions to motor cable length.
	Standard distribution transformer can be used in step up solutions.	High starting torque is available with special transformer design.
	Less motor noise.	Usually the motor fan is the biggest noise source with sine filter solutions.
AP programming, advanced IR-compensation and flux control	The effects of load changes to motor voltage can be compensated i.e. the motor always has the optimum voltage.	Scalar control is required with sine filters.

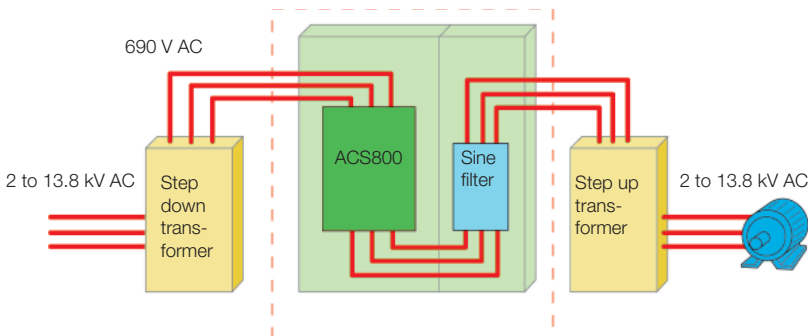

Sine filters

Types and ratings for ACS800-04(M)

$I_{cont,max}$	$P_{cont,max}$	Noise level	Heat dissipation	Air flow	Type designation	Filter size	IP class	Filter	Filter	Filter	Filter	Frame
A	kW	dB	W	m ³ /h				height mm	width mm	depth mm	weight kg	size
U_N = 400 V (Range 380 to 415 V). The power ratings are valid at nominal voltage 400 V.												
8.5	3	67	180	35 ¹⁾	ACS800-04-0005-3	NSIN 0006-5	IP00/IP23	160/234	155/230	120/170	6/9	R2
19	7.5	68	350	69 ¹⁾	ACS800-04-0011-3	NSIN 0016-5	IP00/IP23	280/460	240/470	190/270	15/26	R3
25	11	68	450	69 ¹⁾	ACS800-04-0016-3	NSIN 0020-5	IP00/IP23	280/460	240/470	200/270	19/30	R3
33	15	68	560	69 ¹⁾	ACS800-04-0020-3	NSIN 0025-5	IP00/IP23	280/460	240/470	210/270	21/32	R3
39	18.5	69	630	69 ¹⁾	ACS800-04-0023-3	NSIN 0030-5	IP00/IP23	280/460	240/470	220/270	26/37	R3
44	22	69	630	103 ¹⁾	ACS800-04-0025-3	NSIN 0030-5	IP00/IP23	280/460	240/470	220/270	26/37	R4
54	26	69	730	103 ¹⁾	ACS800-04-0030-3	NSIN 0040-5	IP00/IP23	315/460	300/470	228/270	34/45	R4
58	28	69	730	103 ¹⁾	ACS800-04-0035-3	NSIN 0040-5	IP00/IP23	315/460	300/470	228/270	34/45	R4
72	35	73	950	250 ¹⁾	ACS800-04-0040-3	NSIN 0050-5	IP00/IP23	315/510	300/580	240/325	37/53	R5
86	42	73	1100	250 ¹⁾	ACS800-04-0050-3	NSIN 0060-5	IP00/IP23	320/510	300/580	270/325	53/69	R5
102	52	73	1500	250 ¹⁾	ACS800-04-0060-3	NSIN 0070-5	IP00/IP23	415/510	360/580	210/325	66/82	R5
125	63	75	1800	250 ¹⁾	ACS800-04-0075-3	NSIN 0100-5	IP00/IP23	415/620	360/700	225/425	69/99	R5
164	84	75	2200	405 ¹⁾	ACS800-04-0100-3	NSIN 0120-5	IP00/IP23	415/620	360/700	240/425	75/105	R6
199	102	75	2700	405 ¹⁾	ACS800-04-0120-3	NSIN 0140-5	IP00/IP23	450/620	400/700	500/525	120/165	R6
225	110	79	3900	1105 ²⁾	ACS800-04-0135-3	NSIN 0315-6	IP00	2060	400	600	230	R6
260	130	79	5500	1105 ²⁾	ACS800-04-0205-3	NSIN 0315-6	IP00	2060	400	600	230	R6
206	100	79	4100	1240 ²⁾	ACS800-04(M)-0140-3	NSIN 0315-6 ³⁾	IP00	2060	400	600	230	R7
248	120	79	4900	1240 ²⁾	ACS800-04(M)-0170-3	NSIN 0315-6 ³⁾	IP00	2060	400	600	230	R7
266	130	79	5600	1240 ²⁾	ACS800-04(M)-0210-3	NSIN 0315-6 ³⁾	IP00	2060	400	600	230	R7
445	215	80	8800	1920 ²⁾	ACS800-04(M)-0260-3	NSIN 0485-6 ³⁾	IP00	2060	400	600	250	R8
521	250	80	9700	3220 ²⁾	ACS800-04(M)-0320-3	NSIN 0900-6 ³⁾	IP00	2120	1000	600	690	R8
602	295	80	11100	3220 ²⁾	ACS800-04(M)-0400-3	NSIN 0900-6 ³⁾	IP00	2120	1000	600	690	R8
693	340	80	12100	3220 ²⁾	ACS800-04(M)-0440-3	NSIN 0900-6 ³⁾	IP00	2120	1000	600	690	R8
720	350	80	12600	3220 ²⁾	ACS800-04(M)-0490-3	NSIN 0900-6 ³⁾	IP00	2120	1000	600	690	R8
U_N = 500 V (Range 380 to 500 V). The power ratings are valid at nominal voltage 500 V.												
8.1	4.4	67	200	35 ¹⁾	ACS800-04-0006-5	NSIN 0006-5	IP00/IP23	160/234	155/230	120/170	6/9	R2
19	11	68	440	69 ¹⁾	ACS800-04-0016-5	NSIN 0016-5	IP00/IP23	280/460	240/470	190/270	15/26	R3
25	15	68	550	69 ¹⁾	ACS800-04-0020-5	NSIN 0020-5	IP00/IP23	280/460	240/470	200/270	19/30	R3
33	20	68	600	69 ¹⁾	ACS800-04-0025-5	NSIN 0025-5	IP00/IP23	280/460	240/470	210/270	21/32	R3
37	23	68	600	69 ¹⁾	ACS800-04-0028-5	NSIN 0025-5	IP00/IP23	280/460	240/470	210/270	21/32	R3
42	26	69	700	103 ¹⁾	ACS800-04-0030-5	NSIN 0030-5	IP00/IP23	280/460	240/470	220/270	26/37	R4
47	29	69	900	103 ¹⁾	ACS800-04-0040-5	NSIN 0040-5	IP00/IP23	315/460	300/470	228/270	34/45	R4
56	34	69	900	103 ¹⁾	ACS800-04-0045-5	NSIN 0040-5	IP00/IP23	315/460	300/470	228/270	34/45	R4
65	40	73	1100	250 ¹⁾	ACS800-04-0050-5	NSIN 0050-5	IP00/IP23	315/510	300/580	240/325	37/53	R5
79	48	73	1300	250 ¹⁾	ACS800-04-0060-5	NSIN 0060-5	IP00/IP23	320/510	300/580	270/325	53/69	R5
94	60	73	1800	250 ¹⁾	ACS800-04-0070-5	NSIN 0070-5	IP00/IP23	415/510	360/580	210/325	66/82	R5
125	78	75	2500	250 ¹⁾	ACS800-04-0105-5	NSIN 0100-5	IP00/IP23	415/620	360/700	225/425	69/99	R5
155	99	75	2500	405 ¹⁾	ACS800-04-0120-5	NSIN 0120-5	IP00/IP23	415/620	360/700	240/425	75/105	R6
177	114	75	3500	405 ¹⁾	ACS800-04-0140-5	NSIN 0140-5	IP00/IP23	450/620	400/700	500/525	120/165	R6
225	137	79	4600	1105 ²⁾	ACS800-04-0165-5	NSIN 0315-6	IP00	2060	400	600	230	R6
260	160	79	6100	1105 ²⁾	ACS800-04-0255-5	NSIN 0315-6	IP00	2060	400	600	230	R6
196	125	79	4300	1240 ²⁾	ACS800-04(M)-0170-5	NSIN 0315-6 ³⁾	IP00	2060	400	600	230	R7
245	150	79	5400	1240 ²⁾	ACS800-04(M)-0210-5	NSIN 0315-6 ³⁾	IP00	2060	400	600	230	R7
258	160	79	6200	1240 ²⁾	ACS800-04(M)-0260-5	NSIN 0315-6 ³⁾	IP00	2060	400	600	230	R7
440	275	80	9600	1920 ²⁾	ACS800-04(M)-0320-5	NSIN 0485-6 ³⁾	IP00	2060	400	600	250	R8
515	320	80	11100	3220 ²⁾	ACS800-04(M)-0400-5	NSIN 0900-6 ³⁾	IP00	2120	1000	600	690	R8
550	345	80	11100	3220 ²⁾	ACS800-04(M)-0440-5	NSIN 0900-6 ³⁾	IP00	2120	1000	600	690	R8
602	375	80	11900	3220 ²⁾	ACS800-04(M)-0490-5	NSIN 0900-6 ³⁾	IP00	2120	1000	600	690	R8
684	430	80	13400	3220 ²⁾	ACS800-04(M)-0550-5	NSIN 0900-6 ³⁾	IP00	2120	1000	600	690	R8
700	440	80	14100	3220 ²⁾	ACS800-04(M)-0610-5	NSIN 0900-6 ³⁾	IP00	2120	1000	600	690	R8
U_N = 690 V (Range 525 to 690 V). The power ratings are valid at nominal voltage 690 V.												
13	10.6	67	400	103 ¹⁾	ACS800-04-0011-7	NSIN 0011-7	IP00/IP23	280/460	240/470	190/270	20/31	R4
17	14	67	460	103 ¹⁾	ACS800-04-0016-7	NSIN 0020-7	IP00/IP23	280/460	240/470	220/270	26/37	R4
22	18	68	560	103 ¹⁾	ACS800-04-0020-7	NSIN 0020-7	IP00/IP23	280/460	240/470	220/270	26/37	R4
25	21	68	650	103 ¹⁾	ACS800-04-0025-7	NSIN 0025-7	IP00/IP23	320/510	300/580	222/325	35/51	R4
31	26	69	740	103 ¹⁾	ACS800-04-0030-7	NSIN 0040-7	IP00/IP23	320/510	300/580	235/325	40/56	R4
34	29	70	820	103 ¹⁾	ACS800-04-0040-7	NSIN 0040-7	IP00/IP23	320/510	300/580	235/325	40/56	R4
48	40	73	1000	250 ¹⁾	ACS800-04-0050-7	NSIN 0060-7	IP00/IP23	330/510	300/580	275/325	57/73	R5
52	46	73	1200	250 ¹⁾	ACS800-04-0060-7	NSIN 0060-7	IP00/IP23	330/510	300/580	275/325	57/73	R5
79	69	75	1500	405 ¹⁾	ACS800-04-0070-7	NSIN 0070-7	IP00/IP23	415/510	360/580	240/325	75/91	R6
93	82	75	1900	405 ¹⁾	ACS800-04-0100-7	NSIN 0120-7	IP00/IP23	500/510	420/580	290/325	126/142	R6
104	92	75	2300	405 ¹⁾	ACS800-04-0120-7	NSIN 0120-7	IP00/IP23	500/510	420/580	290/325	126/142	R6
134	113	79	3800	1105 ²⁾	ACS800-04-0145-7	NSIN 0210-6 ³⁾	IP00	2060	400	600	250	R6
148	125	79	4700	1105 ²⁾	ACS800-04-0175-7	NSIN 0210-6 ³⁾	IP00	2060	400	600	250	R6
130	115	78	4000	540 ²⁾	ACS800-04(M)-0140-7	NSIN 0210-6 ³⁾	IP00	2060	400	600	250	R7
142	125	79	4600	540 ²⁾	ACS800-04(M)-0170-7	NSIN 0210-6 ³⁾	IP00	2060	400	600	250	R7
169	150	79	6000	1240 ²⁾	ACS800-04(M)-0210-7	NSIN 0210-6 ³⁾	IP00	2060	400	600	250	R7
315	280	80	9000	1920 ²⁾	ACS800-04(M)-0320-7	NSIN 0485-6 ³⁾	IP00	2060	400	600	250	R8
336	300	80	9700	1920 ²⁾	ACS800-04(M)-0400-7	NSIN 0485-6 ³⁾	IP00	2060	400	600	250	R8
367	330	80	10700	1920 ²⁾	ACS800-04(M)-0440-7	NSIN 0485-6 ³⁾	IP00	2060	400	600	250	R8
444	395	80	12300	1920 ²⁾	ACS800-04(M)-0550-7	NSIN 0485-6 ³⁾	IP00	2060	400	600	250	R8

Nominal ratings

$I_{cont,max}$ Rated current of the drive-filter combination available continuously without overload at 40 °C.

Typical ratings

$P_{cont,max}$ Typical motor power.

Notes: Noise level is a combined value for the drive and the filter. Heat dissipation is a combined value for the drive and the filter.

¹⁾ Air flow of the drive.

²⁾ Combined air flow of the drive and the filter.

³⁾ Dimensions are approximations for a cabinet that can house the filter. Weight is on approximate total weight of the cabinet and the filter. The filter is delivered as loose items including choke module, capacitors and cooling fan.

du/dt filters

du/dt filtering suppresses inverter output voltage spikes and rapid voltage changes that stress motor insulation. Additionally, du/dt filtering reduces capacitive leakage currents and high frequency emission of the motor cable as well as high frequency losses and bearing currents in the motor.

Insulated N-end (non-driven end) bearings and/or common mode filters are also required for motor bearing currents with motors bigger than 100 kW. For more information please see the ACS800 hardware manuals.

The need for du/dt filtering depends on the motor insulation. For information on the construction of the motor insulation, consult the manufacturer. If the motor does not fulfil the following requirements, the lifetime of the motor might decrease.

Filter selection table for ACS800

Motor type	Nominal mains voltage (U_N)	Motor insulation requirement
ABB M2 and M3 motors	$U_N \leq 500 \text{ V}$	Standard insulation system.
	$500 \text{ V} < U_N \leq 600 \text{ V}$	Standard insulation system in conjunction with du/dt filtering or reinforced insulation.
	$600 \text{ V} < U_N \leq 690 \text{ V}$	Reinforced insulation system in conjunction with du/dt filtering.
ABB form-wound HXR and AM motors	$380 \text{ V} < U_N \leq 690 \text{ V}$	Standard insulation system.
ABB random-wound HXR and AM motors	$380 \text{ V} < U_N \leq 690 \text{ V}$	Check motor insulation system with the motor manufacturer. du/dt filtering with voltages over 500 V.
Non-ABB Random-wound and Form-wound	$U_N \leq 420 \text{ V}$	Insulation system must withstand $\hat{U}_{LL}=1300 \text{ V}$.
	$420 \text{ V} < U_N \leq 500 \text{ V}$	If the insulation system withstands $\hat{U}_{LL}=1600 \text{ V}$ and $\Delta t=0.2 \mu\text{s}$, du/dt filtering is not required. With du/dt filtering, the insulation system must withstand $\hat{U}_{LL}=1300 \text{ V}$.
	$500 \text{ V} < U_N \leq 600 \text{ V}$	If the insulation system withstands $\hat{U}_{LL}=1800 \text{ V}$, du/dt filtering is not required. With du/dt filtering, the insulation system must withstand $\hat{U}_{LL}=1600 \text{ V}$.
	$600 \text{ V} < U_N \leq 690 \text{ V}$	If the motor insulation system withstands $\hat{U}_{LL}=2000 \text{ V}$ and $\Delta t=0.3 \mu\text{s}$, du/dt filtering is not required. With du/dt filtering, the insulation system must withstand $\hat{U}_{LL}=1800 \text{ V}$.

Symbol	Explanation
U_N	Nominal mains voltage.
\hat{U}_{LL}	Peak line to line voltage at motor terminals.
Δt	Rise time, i.e. interval during which line to line voltage at motor terminals changes from 10 to 90% of full voltage range.

Standard user interface

Standard I/O

Analog and digital I/O channels are used for different functions such as control, monitoring and measurement purposes (e.g. motor temperature). In addition, optional I/O extension modules are available providing additional analog or digital I/O connections.

Standard I/O on RMIO-11 board

- 3 analog inputs: differential, common mode voltage ± 15 V, galvanically isolated as a group
 - One $\pm 0(2)$ to 10 V, resolution 12 bit
 - Two 0(4) to 20 mA, resolution 11 bit
- 2 analog outputs:
 - 0(4) to 20 mA, resolution 10 bit
- 7 digital inputs: galvanically isolated as a group (can be split in two groups)
 - Input voltage 24 V DC
 - Filtering (HW) time 1 ms
- 3 digital (relay) outputs:
 - Changeover contact
 - 24 V DC or 115/230 V AC
 - Max. continuous current 2 A
- Reference voltage output:
 - ± 10 V $\pm 0.5\%$, max. 10 mA
- Auxiliary power supply output:
 - +24 V $\pm 10\%$, max. 250 mA

Below are the standard drive control I/O of the ABB industrial drive with Factory Macro. For other ACS800 application macros the functions may be different.

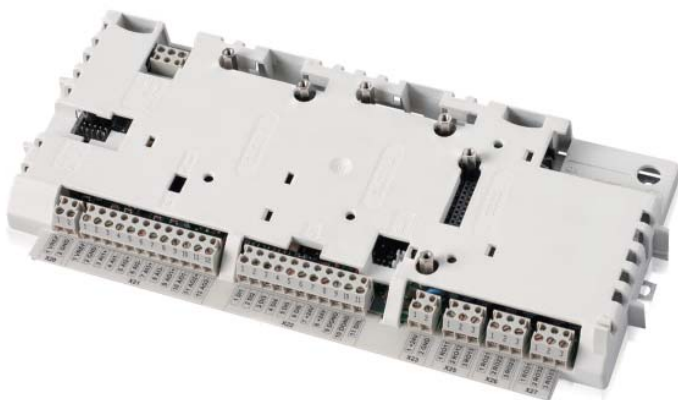
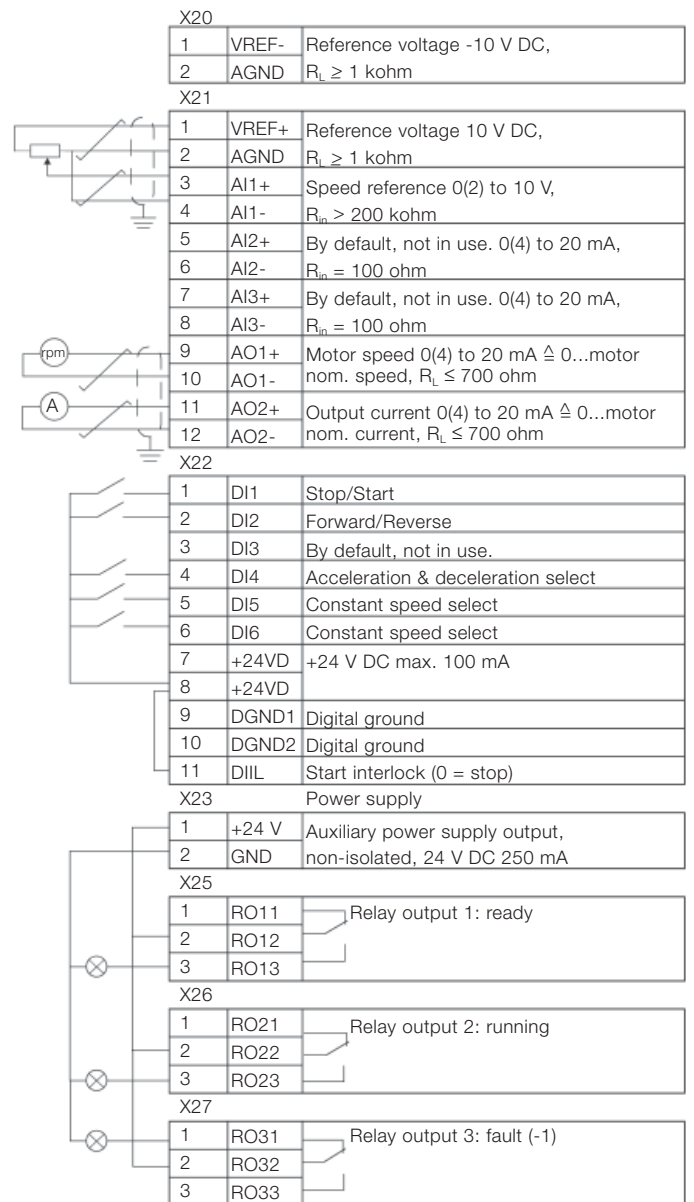

Options

Control panel

Control panel mounting platforms

The industrial drive control panel (+J400) has a multi-lingual alphanumeric display (4 lines x 20 characters) with plain text messages in 14 languages.

The control panel is removable and can be mounted on the drive enclosure or remotely.

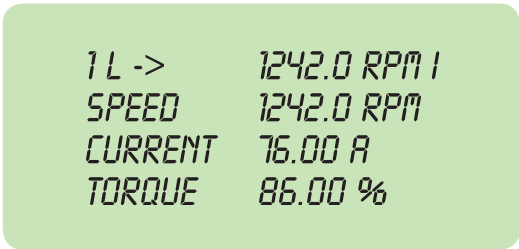

Start-up assistant

Easy commissioning with the start-up assistant in standard control program. The start-up assistant actively guides you through the commissioning procedure step by step. It also has a unique on-line help function.

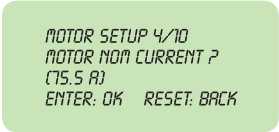

Actual value display

The control panel can display three separate actual values simultaneously.

Examples of these are:

- Motor speed
- Frequency
- Current
- Torque
- Power
- References
- DC bus voltage
- Output voltage
- Heatsink temperature
- Operating hours
- Kilowatt hours

Fault memory

A built-in fault memory stores information relating to the latest 64 faults, each with a time stamp.

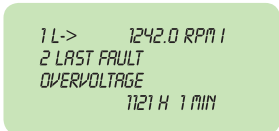

Parameter copying

The parameter copy feature allows all drive parameters to be copied from one frequency converter to another to simplify commissioning.

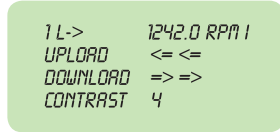

Centralised control

One panel can control up to 31 drives.

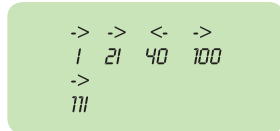

Easy programming

Parameters are organised into groups for easy programming.

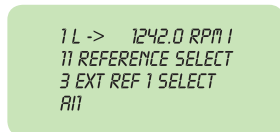

Control panel mounting platforms (+J410 and +J413)

On the reverse of the control panel are screw holes from where the control panel can be fixed to a cabinet door. Panel-mounting platforms, which allow the panel to be removed, are also available. There are two variants of the panel-mounting platform:

RPMP-11 (+J410) for door mounting

RPMP-21 (+J413) for panel mounting inside the cabinet

Options

Optional I/O

Standard I/O can be extended by using analog and digital extension modules or pulse encoder interface modules which are mounted in the slots on the ACS800 control board. The control board has two slots available for extension modules. More extension modules can be added with the I/O extension adapter which has three slots. The available number and combination of I/O's depends on the control software used. The standard application software supports 1 analog and 3 digital extension modules.

Optional I/O

Analog I/O extension module RAIO-01 (+L500)

- 2 analog inputs: galvanically isolated from 24 V supply and ground
 - $\pm 0(2)$ to 10 V, 0(4) to 20 mA or ± 0 to 2 V, resolution 12 bits
- 2 analog outputs: galvanically isolated from 24 V supply and ground
 - 0(4) to 20 mA, resolution 12 bit

Digital I/O extension module RDIO-01 (+L501)

- 3 digital inputs: individually galvanically isolated
 - Signal level 24 to 250 V DC or 115/230 V AC
- 2 relay (digital) outputs:
 - Changeover contact
 - 24 V DC or 115/230 V AC
 - Max. 2 A

Pulse encoder interface module RTAC-01 (+L502)

- 1 incremental encoder input:
 - Channels A, B and Z (zero pulse)
 - Signal level and power supply for the encoder is 24 or 15 V
 - Single ended or differential inputs
 - Maximum input frequency 200 kHz

I/O extension adapter AIMA-01

- Three slots for I/O extension modules
- Connection to the ACS800 control board through optic link
- Dimensions: 78 × 325 × 28 mm
- Mounting: onto 35 × 7.5 mm DIN rail
- External power supply connection
- Supply voltage: 24 V DC \pm 10%
- Current consumption: depends on connected I/O extension modules



Analog I/O extension module
RAIO-01



Pulse encoder interface module
RTAC-01



I/O extension adapter
AIMA-01

Options

Fieldbus control

ABB industrial drives have connectivity to major automation systems. This is achieved with a dedicated gateway concept between the fieldbus systems and ABB drives.

The fieldbus gateway module can easily be mounted inside the drive. Because of the wide range of fieldbus gateways, your choice of automation system is independent of your decision to use first-class ABB AC drives.

Manufacturing flexibility

Drive control

The drive control word (16 bit) provides a wide variety of functions from start, stop and reset to ramp generator control. Typical setpoint values such as speed, torque and position can be transmitted to the drive with 15 bit accuracy.

Drive monitoring

A set of drive parameters and/or actual signals, such as torque, speed, position, current etc., can be selected for cyclic data transfer providing fast data for operators and the manufacturing process.

Drive diagnostics

Accurate and reliable diagnostic information can be obtained via the alarm, limit and fault words, reducing the drive downtime and therefore also the downtime of the manufacturing process.

Drive parameter handling

Total integration of the drives in the production process is achieved by single parameter read/write up to complete parameter set-up or download.



Reduced installation and engineering effort

Cabling

Substituting the large amount of conventional drive control cabling with a single twisted pair reduces costs and increases system reliability.

Design

The use of fieldbus control reduces engineering time at installation due to the modular structure of the hardware and software.

Commissioning and assembly

The modular machine configuration allows pre-commissioning of single machine sections and provides easy and fast assembly of the complete installation.

Currently available gateways

Fieldbus	Protocol	Device profile	Baud rate
PROFIBUS (+K454)	DP, DPV1	PROFdrive ABB Drives*)	9.6 kbit/s - 12 Mbit/s
DeviceNet™ (+K451)	-	AC/DC drive ABB Drives*)	125 kbit/s - 500 kbit/s
CANopen (+K457)	-	Drives and motion control ABB Drives*)	10 kbit/s - 1 Mbit/s
ControlNet (+K462)	-	AC/DC drive ABB Drives*)	5 Mbit/s
Modbus (+K458)	RTU	ABB Drives*)	600 bit/s - 19.2 kbit/s
Ethernet (+K466)	EtherNet IP™ Modbus/TCP	ABB Drives*), AC/DC drive ABB Drives*)	10 Mbit/s / 100 Mbit/s
Ethernet (+K467)	PROFINET IO Modbus/TCP	PROFdrive ABB Drives*)	10 Mbit/s / 100 Mbit/s
InterBUS-S (+K453)	I/O, PCP	ABB Drives*)	500 kbit/s
LonWorks® (+K452)	LonTalk®	Variable speed motor drive	78 kbit/s
EtherCAT® (+K469)	EtherCAT®	Drive and motion control ABB Drives*)	100 Mbit/s
Ethernet POWERLINK (+K470)	Ethernet POWERLINK	Drive and motion control ABB Drives*)	100 Mbit/s

*) Vendor specific profile

Options

Remote monitoring and diagnostics tool

Browser-based, user-friendly

The intelligent ethernet NETA-01 module gives simple access to the drive via the internet, communicating via a standard web browser. The user can set up a virtual monitoring room wherever there is a PC with an Internet connection or via a simple dial-up modem connection. This enables remote monitoring, configuration, diagnostics and, when needed, control. The drive can also provide process related information, such as load level, run time, energy consumption and I/O data, the bearing temperature of the driven machine, for instance.

This opens up new possibilities for the monitoring and maintenance of unmanned applications across a range of industries, for instance water, wind power, building services and oil & gas, as well as any application where the user needs access to the drives from more than one location. It also provides an opportunity for OEMs and system integrators to support their installed base globally.

No PC needed at local end

The intelligent ethernet module has an embedded server with the necessary software for the user interface, communication and data storage. This gives ease of access, realtime information and the possibility for two-way communication with the drive, enabling immediate response and actions, saving time and money. This is possible without using a PC at the local end, as required by other remote solutions.

Powerful and versatile

Up to nine drives can be connected to the intelligent ethernet module via fiber optic links. It is available as an option for new drives, as well as an upgrade for existing systems. Access to the module is secured by user ID and passwords.

With an additional Modbus TCP/OPC server the information provided by NETA-01 can be integrated with the monitoring systems.

Features

- Virtual monitoring room for
 - Monitoring
 - Configuration of parameters
 - Diagnostics
 - Control, if needed
- Browser-based access via
 - Intra-/extra-/internet or
 - Simple dial-up modem connection
- No PC needed at the local end
- Can be used as a Modbus/TCP bridge for process control
- Supports integration with SCADA systems



Standard control program

Standard control program

Based on direct torque control technology, the ACS800 offers highly advanced features as standard. The ACS800 standard control program provides solutions to virtually all AC drives applications such as pumps, fans, extruders and conveyors to name few.

Adaptive programming

In addition to parameters, industrial drives have the possibility for function block programming as standard. Adaptive programming with 15 programmable function blocks makes it possible to replace e.g. relays or even a PLC in some applications. Adaptive programming can be done either by standard control panel or DriveAP, a user-friendly PC tool.

The standard application macros

The ACS800 features built-in, pre-programmed application macros for configuration of such parameters as inputs, outputs and signal processing.

- FACTORY SETTINGS for basic industrial applications
- HAND/AUTO CONTROL for local and remote operation
- PID CONTROL for closed loop processes
- SEQUENTIAL CONTROL for repetitive cycles
- TORQUE CONTROL for processes where torque control is required
- USER MACRO 1 & 2 for user's own parameter settings

Software features

A complete set of standard software features offers premium functionality and flexibility.

- Accurate speed control
- Accurate torque control without speed feedback
- Adaptive programming
- Automatic reset
- Automatic start
- Constant speeds
- Controlled torque at zero speed
- DC hold
- DC magnetizing
- Diagnostics
- Flux braking
- Flux optimization
- IR compensation
- Master/follower control
- Mechanical brake control
- Motor identification
- Parameter lock
- Power loss ride-through
- Process PID control

- Programmable I/O
- Scalar control
- Speed controller tuning
- Start-up assistant
- Support for sine filter in the drive output
- Trim function
- User-selectable acceleration and deceleration ramps
- User adjustable load supervision/limitation

Pre-programmed protection functions

A wide range of features provides protection for the drive, motor and the process.

- Ambient temperature
- DC overvoltage
- DC undervoltage
- Drive temperature
- Input phase loss
- Overcurrent
- Power limits
- Short circuit

Programmable protection functions

- Adjustable power limits
- Control signal supervision
- Critical frequencies lock-out
- Current and torque limits
- Earth fault protection
- External fault
- Motor phase loss
- Motor stall protection
- Motor thermal protection
- Motor underload protection
- Panel loss

Optional control programs

Control solutions for different applications

ABB provides a set of ready-made control solutions for specific industrial drive applications. Such software adds application-dedicated features and protection without an external PLC - improving productivity and reducing costs. Function blocks are easy to program using the DriveAP PC tool.

Main advantages of ABB's control solutions

- Application-dedicated features
- Improved production
- No external PLC
- User-friendly
- Easy to use
- Energy savings
- Smooth power loss ride-through
- Reduced costs
- Adaptive protection

Multiblock control program

The multiblock control program has been specially designed for system integrators and local engineering because of its flexibility, easy programming, large number of I/O, master-follower link and fieldbus interfaces. Integrated into the drive control board there are over 200 function blocks on 3 time levels: 20 ms, 100 ms and 500 ms. These benefits mean that it is not always necessary to have separate PLC for drive and process control. Function blocks are easy to program using the DriveAP PC tool.

Extended I/O

An analog and digital I/O extension is typically installed on the AIMA-01 I/O extension adapters. Three extension modules can be installed on each I/O extension adapter. The maximum number of I/O connections is 62.

Motion control program

The motion control program is a cost-effective solution for precision positioning and synchronization. Intelligent integrated motion control functions and versatile controllability eliminate the need for an external motion controller, even in the most demanding applications, such as materials handling, packaging, printing and the plastics industry.

Motion control program has four operating modes – speed, torque, positioning and synchronization – and also provides the possibility for switching online between two selected modes.

Pump control program

Incorporating all functions commonly required at pumping facilities, pump control program eliminates the need for an external PLC and can help to save energy, reduce downtime, and prevent pump jamming and pipeline blocking. It is easy-to-use software, designed to meet the needs of water and waste utilities, industrial plants and other pump users.

Application base control program

The application base control program is a simple, ready-made application that can easily be modified using a special function block programming tool. The application engineer can easily modify the time levels and insert new functions to control the I/O, start/stop commands, and references etc. This is the most flexible software product for tailor-made customer applications.

Winder and inline control programs

Winder and inline control programs utilize the accurate speed and torque control of the drive in controlling product tension within a process by adjusting the speed or torque, based on the dancer or tension feedback. This precise control ensures high-quality handling of web material. The result is a straightforward, cost-effective solution in web handling applications. Winder control program supports adaptive programming with 15 blocks.



Optional control programs

Control solutions for different applications

Rod pump and PCP/ESP pump control programs

These pump control programs have been specially developed in close cooperation with the oil industry for artificial oil lifting applications. The products not only increase the production and pump efficiency, but also reduce the stress on the complete pump system. The benefits provided include enhanced equipment protection, optimised fluid production, and overall improvement of system performance.

Permanent magnet synchronous motor (PMSM) control program

This control program is available with standard control application and system control application. The motor control software is specially made for permanent magnet low-speed – high-torque motors. This offers precise and reliable control at low speed without speed feedback. Permanent magnet software supports adaptive programming with 15 blocks.

Centrifuge control program

- Practical programmable sequences for conventional centrifuges.
- Integrated decanter control for the accurate speed difference control of two shafts, where direct communication via the fibre optic link between bowl and scroll is used.
- Centrifuge control program supports adaptive programming with 15 blocks.

Crane control program

This control program is designed for different kinds of crane motions - mainly for hoist, trolley and long travel motions.

The ABB crane control program is a flexible control platform, which enables a wide range of connectivity for start, stop and reference logic. Adaptive programming with 15 blocks gives additional flexibility for tailor-made modifications outside the ready-made parameter structure. This is like having a small PLC inside the drive.

Reliable, integrated brake control logic for smooth open and close logic without jerks improves operational safety and performance. Brake acknowledge, torque memory and pre-magnetisations are the key software elements that ensure reliable control.

Different functions as standard increase the safety level of the crane. These include integrated speed match, speed monitor, fast stop, slowdown and end limit logic.

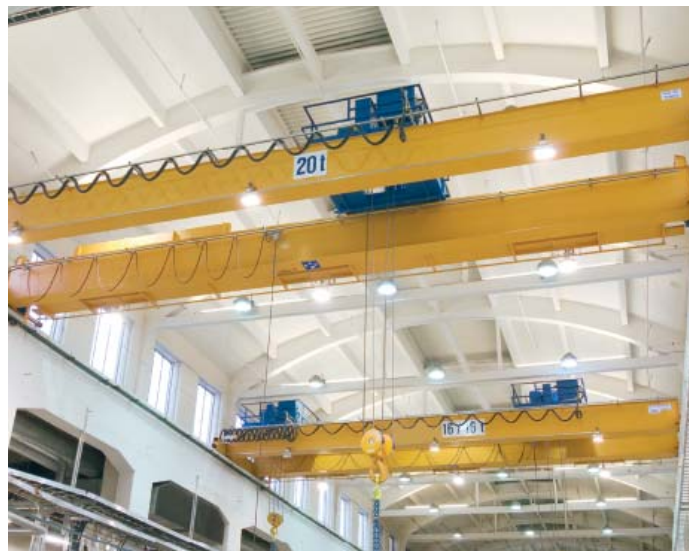

The master-follower logic for up to five motors enables common drum or separate motors with load sharing, or with separate drums and separate motors with shaft synchro control. Fast switchover logic between stand-alone and master-follower logic increases the operational productivity. Internal homing control logic for position-controlled cranes can also be done with ready-made parameters. The position measurement enables position actual signals in millimeters for further logic.

The load speed control enables optimization of the hoist speed for different loads.

The integrated service counters for maintenance logic enable the different counters to provide information.

An easy-to-use, ready-made solution specifically for cranes.

Cranedrive control program

A cranedrive control with optimal operational safety and performance built into the drive.

- A fixed, standard and ready-made crane application for different crane applications such as harbor cranes.
- Optimal operational safety and performance built into the drive.
- Ready-to-use with proven crane functionality.
- Available as single-drive or multi-drive with dynamic and regenerative braking.

Standard, ready-to-use crane solution.

Optional control programs

Control solutions for different applications

Master/follower control

Reliable control via the fibre optic link of several drives controlled by one master. This is needed if the motor shafts are coupled together, for example. The master/follower function enables the load to be evenly distributed between the drives.

Spinning control and traverse control program

Spinning control and traverse control program make a perfect pair for the precise control of spinning and traverse drives in textile machines.

System control program

This control program is aimed at multi-motor machines producing or processing metal, paper, plastics, textile, rubber and cement, and for numerous other demanding applications. Fast communication with the overriding controller can exchange operative data (references, command words) and support data (configuration data, diagnostics). Proprietary (DDCS, Drive bus) and generic (PROFIBUS, InterBUS-S, DeviceNet) protocols enable linking of drives to controllers, PLC and PCs.

Winch control program

ABB industrial drives with winch control program replace traditional and costly hydraulic winch controllers, thereby eliminating high maintenance costs and performance inefficiencies, while improving operator and overall system reliability.

The electrical interface can be traditional I/O based or fieldbus gateways from an overriding PLC and can be used to control the winch directly from control stands located on the port, starboard and upper deck of the vessel.

Anchor control provides stepless speed control of the anchor whether is being raised or lowered.

The tension within the mooring ropes can be controlled either manually (hand-mooring) or automatically (auto-mooring) by automooring sequence.

Ro-Ro quarter ramp control logic is for lifting or lowering the gate ramp, with protection to slowdown the speed and torque before closing the gate ramp in the upper end position.



Dimensioning tool

DriveSize is designed to help select the optimal motor, drive and transformer for the application. Based on user supplied data, the tool calculates and suggests which drive and motors to use. Additionally, the tool can be used to compute currents, network harmonics, and to create documents about dimensioning based on the load data provided. DriveSize uses the technical specifications contained in the ABB motor and drive catalogs.

DriveSize provides default values that can be changed by the user, and provides different options for drive selection. Shortcut keys can be used to quickly navigate around the tool.

Motors, drives, and transformers

DriveSize can accommodate technical information for the following:

- 3-phase standard, customized, EX, and user defined motors
- ABB low voltage AC drives
- Transformers

Highlights

- Select optimal motor, drive, and transformer
- Calculate network harmonics for a single supply unit, or the whole system
- Import user defined motor database
- View dimensioning results graphically and numerically
- Print and save results

DriveSize can be downloaded free from www.abb.com/drives. Follow the PC Tools link.

The screenshot shows the ABB website's 'EngineeringDriveSize' page. The header includes the ABB logo and navigation links like 'Home', 'About ABB', 'Products & Services', etc. The breadcrumb trail reads: 'Product Guide > Motors, Drives and Power electronics > Drives > PC tools > EngineeringDriveSize'. The main content area is titled 'DriveSize' and contains the following text:

DriveSize is a PC program to help select an optimal motor, frequency converter and transformer particularly in cases where a straightforward selection from a catalogue is not possible. DriveSize can also be used to compute network harmonics and to create documents about the dimensioning. It contains current versions of our motor and frequency converter catalogues.

The DriveSize software can be used in Win98, WinNT, Win2000 and WinXP operating systems. For installation instruction check the README.pdf. DriveSize has eight parts covering ACS 800 multidives, ACS800 single drives, ACS600 multidives, ACS600 single drives, ACS550, ACH550, ACS400 Drives 3ph and Direct on line motors.

Link to [DriveSize Software](#).
You have to register, before you can download the software.

Any feedback concerning DriveSize is welcome at [Drive Care - Support \(drive.care@fi.abb.com\)](mailto:drive.care@fi.abb.com) e-mail address.

At the bottom of the page, there are links for 'Printer version', 'Email this page', and 'Bookmark this page', along with a footer: 'Provider information/Impressum © Copyright ABB. All rights reserved'.

DriveWindow

Start-up and maintenance tool

A tool for the entire life cycle DriveWindow is designed to support the daily operation of ABB low voltage industrial drives. The tool provides users with capabilities to view, edit, and set drive parameters, as well as advanced functions like drive backup and data logger views. DriveWindow connects to drives using a disturbance free high speed fiber optic network.

Drive startup and maintenance

DriveWindow is used to configure drive parameters during drive commissioning. Drive parameter configuration files can be saved and used to commission new drives or kept as backups. DriveWindow provides a complete listing of the drive parameters and their corresponding values allowing users to view and edit individual parameters. Using the built-in data and fault loggers, users are able to monitor signals and real-time status of the drive. This data can be used for graphical trending of the drive's performance. The data and fault loggers come with functions allowing users to process the data.

PC based drive control

DriveWindow provides a built-in drive control panel allowing users to start, stop, set the direction, speed, and torque reference values of the connected drive.

High speed data access

High speed connections between DriveWindow and drives via the DDCS fiber optic network can be made. The fast access enables oscilloscope-like functionality in the data logger view, where drive information can be viewed graphically and also saved to file.

Highlights

- View and set drive parameters
- Monitor drive signals, graphically and numerically
- Use high speed data connection to the drive
- Save and compare drive configuration files
- Control the drive using the built-in control panel
- Tune the drives performance OPC server
- Connects via USB to the DDCS network

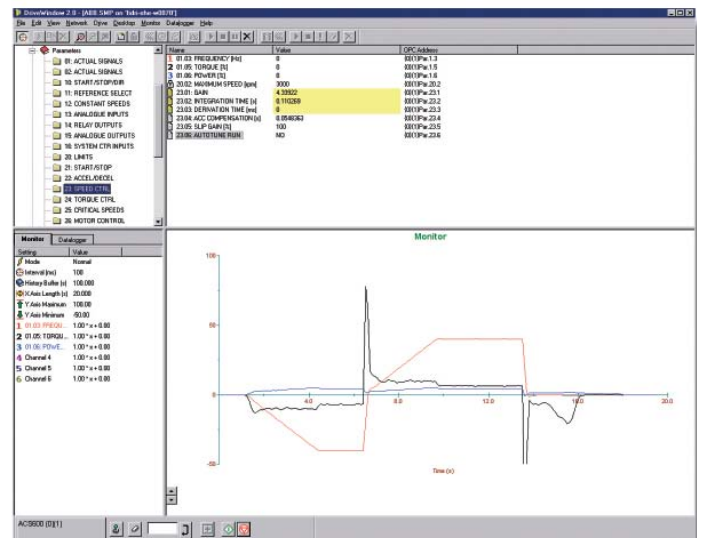

Programming tool

DriveAP is a programming tool for creating, editing and documenting adaptive and multi-block programs. Fifteen function blocks are available for adaptive programming, and over 200 function blocks as well as PROFIBUS and drives I/O blocks may be edited using multi-block programming.

DriveAP supports IEC 61131 and only requires users to have a basic knowledge of block programming in order to use the tool. No special programming knowledge is needed.

Adaptive programs are easy to document either as printed copies or as stored files on the PC.

Operating modes

Stand-alone mode, DriveAP is not connected to a drive. The adaptive programming and multi-block programming can be done in the office and later downloaded to the drive.

Off-line mode, DriveAP is connected to a drive. The adaptive programming and multi-block programming can be carried out in batch mode.

On-line mode, DriveAP is connected to a drive. Changes to the adaptive or multi-block programs are written immediately to the drive and the actual values are shown on the screen in real-time.

DriveAP features

- Create and modify adaptive programs
- Create and modify multi-block programs
- Document programs
- Read existing program from the drive
- Stand-alone mode
- Off-line mode
- On-line mode

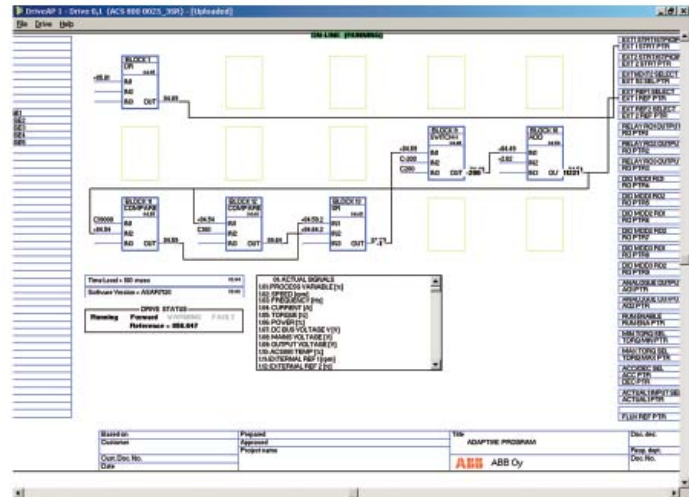

DriveAP with adaptive program of standard application.

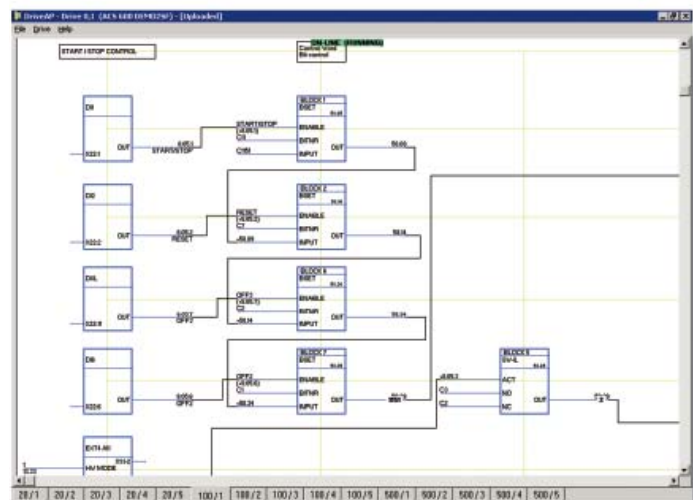

DriveAP with multiblock programming application.

DriveAnalyzer

Start-up and maintenance tool

DriveAnalyzer is a PC tool designed to perform analysis on ABB industrial single drive's performance. The results of the analysis can be used to help tune the drive to achieve better efficiencies and performance of the driven process.

Motor mechanical loads and performance data is recorded by DriveAnalyzer as the basis for the analysis. The tool is not a fault diagnosis tool, it is designed to work with operational drives using the standard control or system control programs. Drive data is collected over time enabling duration graphing and longer run time analysis.

DriveAnalyzer connects to multiple drives collecting data on the network supply which can be used by engineers to ensure the power supply network is optimized for the driven process.

DriveAnalyzer collects data on mechanical power, torque, rotational speed, energy use (kWh), currents, frequency, electrical power, temperatures, the status word, peak value logger information and amplitude logger information.

Highlights

- Motor and drive utilization
- Motor shaft load shape and duration plots
- Machine load behavior analysis
- Power supply and network analysis
- Energy savings analysis
- Read and show peak values
- Read and show amplitude logger registers
- Export results and reports to spreadsheets

Energy conservation report		ABB
Test_one_full_da		
Measurement started	August 06 2007 05:34:50 PM	
Measurement ended	August 07 2007 10:12:42 AM	
Total length of measurement	16 hr 37 min 52 sec	
Drives included:		
ACS 800 0025_3SR		
Energy cost:		
Day Time	0,06	EUR/kWh
Night Time	0,03	EUR/kWh
ACS 800 0025_3SR		
Actual Energy Consumed		
Energy consumed at day time	21206,77	kWh
Energy consumed at night time	10587,31	kWh
Energy Total	31794,08	kWh
Energy cost day	1272,41	EUR
Energy cost night	317,62	EUR
Energy cost total	1590,03	EUR
Estimated Energy Consumed in Throttle control		
Energy consumed at day time	75960,13	kWh
Energy consumed at night time	70405,88	kWh
Energy Total	146366,01	kWh
Energy cost day	4557,61	EUR
Energy cost night	2112,18	EUR
Energy cost total	6669,78	EUR

DriveAnalyzer energy conservation report

DriveOPC

Integration tool

DriveOPC is a software package which allows OLE for Process Control (OPC) communication between Windows applications and ABB industrial drives. It allows Object Linking and Embedding (OLE) for Process Control (OPC) communication. This OPC server is an ideal tool for integrating ABB industrial drives and commercial PC software, and creating PC based control and monitoring systems.

Remote monitoring

DriveOPC enables remote connection over LAN (local area networks). The remote PC can be connected through its IP address (e.g. "164.12.43.33") or by the DNS name (e.g. "Gitas213").

OPC based software

OPC is an industry standard created in cooperation with Microsoft. It is an open architecture interface design, managed by the international OPC foundation. OPC is meant for different kinds of factory automation. DriveOPC is based on the OPC foundation data access standard 1.0A and Microsoft COM/DCOM technology. DriveOPC has full access to all drives, even when remote connection over LAN is used.

High speed communication

DriveOPC uses the DDCS communication protocol on a highspeed fibre optic network, enabling very fast communication between the PC and drives. The fibre optic network is safe and highly immune to external disturbances. The fibre optic network is connected to the PC using either a USB or communication card adapter.

DriveOPC features

- DriveOPC supports OPC's data access 1.0A.

Read access to:

- Drive status: local, running, direction, fault, warning, reference
- Signals and parameters
- Fault logger contents
- Event logger contents
- General drive information
- Data logger settings, status and contents

Write access to:

- Drive control: local, start, stop, forward, reverse, coast stop, reset fault, home, teach-in, contactor on/off, reference
- Parameters
- Fault logger clear
- Data logger init, start, trig, clear

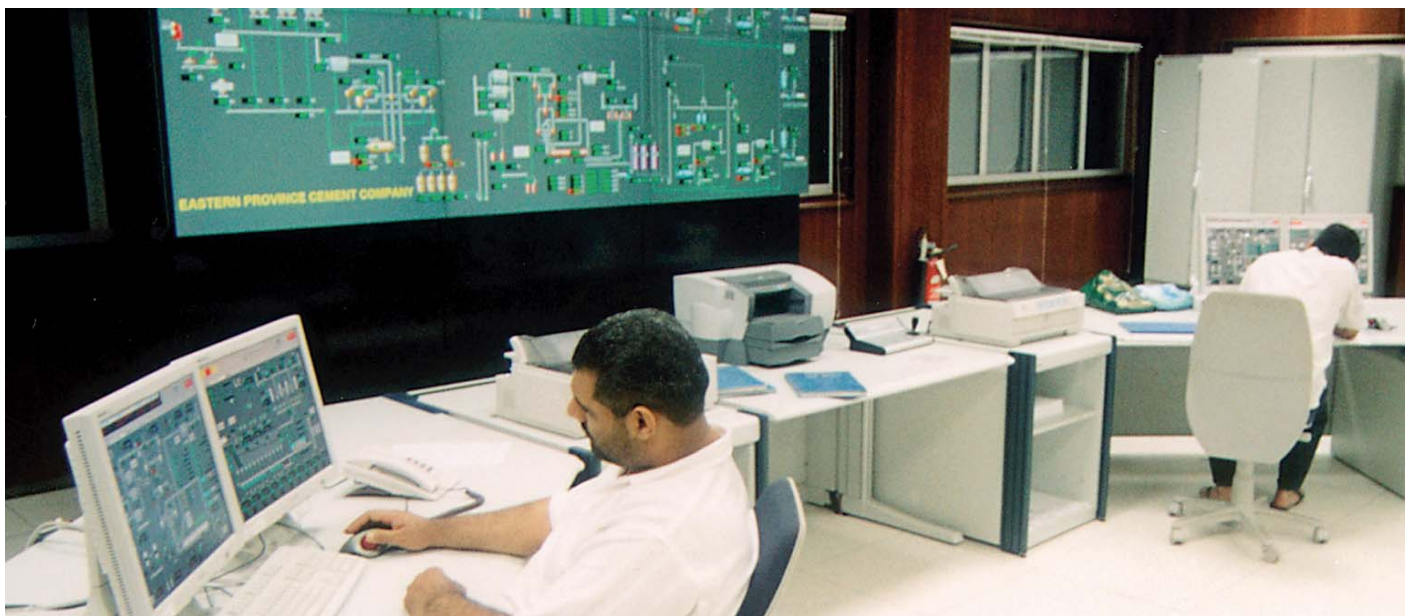

Summary of features and options

Power and voltage range	Ordering code	04	04 (M)	04	14	104 (INU)	204 (ISU)	304 and 704 (DSU)
		Frame sizes R2 to R6	Frame sizes R7 to R8	Frame sizes nxR8i	Frame sizes R7i to nxR8i	Frame sizes R2i to 4*R8i	Frame sizes R2i to 4*R8i	Frame sizes D3 to 5*D4
		230 V: 0.55 to 55 kW 400 V: 1.1 to 160 kW 500 V: 1.5 to 200 kW 690 V: 5.5 to 160 kW	230 V: 45 to 200 kW 400 V: 90 to 400 kW 500 V: 110 to 500 kW 690 V: 90 to 560 kW	400 V: 400 to 1450 kW 500 V: 500 to 1900 kW 690 V: 500 to 1900 kW	400 V: 75 to 1600 kW 500 V: 90 to 1800 kW 690 V: 90 to 1700 kW	400 V: 1.1 to 2400 kW 500 V: 1.5 to 2900 kW 690 V: 5.5 to 2800 kW	400 V: 2.7 to 2555 kW 500 V: 3.1 to 2932 kW 690 V: 105 to 2700 kW	400 V: 147 to 2436 kW 500 V: 183 to 3045 kW 690 V: 253 to 4202 kW
Mounting								
Wall mounting		●	●	–	● 19)	● 10)	● 10)	–
Free-standing		–	● 1)	●	● 15)	● 15)	● 15)	●
Two mounting directions: bookshelf / flat (=sideways)	H354 or H360	–	○	–	–	–	–	–
Side by side mounting		●	●	●	●	●	●	●
Flange mounting	C135	□ 20)	–	–	–	–	–	–
Separate drive control unit (RDCU)		–	●	●	●	● 11)	●	–
Wheels for easy manoeuvring of the module		–	–	●	● 12)	● 12)	● 12)	● 12)
Cabling								
Supply bottom entry (module terminals)		●	–	●	●	● 10)	●	●
Supply top entry (module terminals)		–	●	–	–	● 12)	–	–
Bottom exit (module terminals)	H352	●	○ 2)	●	●	●	–	–
Side exit (module terminals)	H354 or H360	–	● 3)	–	–	–	–	–
Top exit in the module		–	–	–	–	–	●	●
DC and brake chopper output busbars	H356	●	○	–	–	–	–	–
DC and brake chopper outputs on different sides of the module	H363	–	○	–	–	–	–	–
Vertical busbars for easy motor cable connection	H355	–	● 3)	–	–	–	–	–
Vertical busbars for easy DC/ brake chopper cable connection	H362	–	● 3)	–	–	–	–	–
Enclosure class								
IP00 (UL open chassis)		–	●	●	●	●	●	●
IP20 (UL open chassis)	B060	●	○ 4)	–	–	–	–	–
Motor control								
DTC		●	●	●	●	●	●	–
Software 5)								
Start-up assistant		● 6)	● 6)	● 6)	● 6)	● 6)	–	–
Adaptive programming		● 6)	● 6)	● 6)	● 6)	● 6)	–	–
Motion control	N685	□	□	□	□	□	–	–
Optional software optimized for different applications or for enhanced programmability: for more details see section "Application software and programming"		□	□	□	□	□	–	–
Control panel								
Alphanumeric 4*20 character control panel	J400	X	X	■	■	■	■	■
Control panel mounting platform	J410 or J413	■	X	■	■	■	■	■
Control connections (I/O) and communications								
3 pcs analog inputs, programmable, galvanically isolated		●	●	●	● 9)	●	● 9)	● 9)
2 pcs analog outputs, programmable		●	●	●	● 9)	●	● 9)	● 9)
7 pcs digital inputs, programmable, galvanically isolated - can be divided into two groups		●	●	●	● 9)	●	● 9)	● 9)
3 pcs relay outputs, programmable		●	●	●	● 9)	●	● 9)	● 9)
Possibility for external control voltage		●	●	●	●	●	●	●
Built-in I/O extension and speed feedback modules: for more details see section "Control connections and communications"		□	□	□	□	□	–	–
Built-in adapters for several fieldbuses: for more details see section "Control connections and communications"		□	□	□	□	□	□	□

Summary of features and options

Power and voltage range	Ordering code	04	04 (M)	04	14	104 (INU)	204 (ISU)	304 and 704 (DSU)
		Frame sizes R2 to R6	Frame sizes R7 to R8	Frame sizes nxR8i	Frame sizes R71 to nxR8i	Frame sizes R21 to 4*R8i	Frame sizes R21 to 4*R8i	Frame sizes D3 to 5*D4
		230 V: 0.55 to 55 kW 400 V: 1.1 to 160 kW 500 V: 1.5 to 200 kW 690 V: 5.5 to 160 kW	230 V: 45 to 200 kW 400 V: 90 to 400 kW 500 V: 110 to 500 kW 690 V: 90 to 560 kW	400 V: 400 to 1450 kW 500 V: 500 to 1900 kW 690 V: 500 to 1900 kW	400 V: 75 to 1600 kW 500 V: 90 to 1800 kW 690 V: 90 to 1700 kW	400 V: 1.1 to 2400 kW 500 V: 1.5 to 2900 kW 690 V: 5.5 to 2800 kW	400 V: 2.7 to 2555 kW 500 V: 3.1 to 2932 kW 690 V: 105 to 2700 kW	400 V: 147 to 2436 kW 500 V: 183 to 3045 kW 690 V: 253 to 4202 kW
EMC filters								
EMC 1 st environment (Category C2)	E202	□ 7)	X 7)	-	-	-	-	-
EMC 2 nd environment, earthed networks only (Category C3)	E200	□ 16)	-	-	-	-	-	-
EMC 2 nd environment, earthed and unearthed networks (Category C3)	E210	□ 17)	□	-	-	-	-	-
Line filter								
AC or DC choke		●	●	●	-	-	-	●
LCL		-	-	-	●	-	●	-
Output filters								
Common mode filter	E208	-	□	●	●	■ 15)	■ 15)	-
du/dt filters		■	■	●	● 18)	● 13)	-	-
Braking								
Brake chopper	D150	□ 8)	□	■	■	■	-	-
Brake resistor		■	■	■	■	■	-	-
Regenerative braking		-	-	-	●	-	●	-
Rectifier bridge								
6-pulse that can be connected as 12-pulse		-	-	● 14)	-	-	-	● 14)
Line side apparatus								
Built-in load switch		-	-	●	-	-	-	●
Built-in contactor	F250	-	-	-	-	-	-	□
Safety								
Prevention of unexpected start-up	Q950	-	-	□	□	□	-	-
Safe torque-off	Q967	□	□	□	□	□	-	-
Earth fault monitoring, earthed mains		●	●	●	●	●	●	●
Earth fault monitoring, unearthed mains		●	●	●	■	●	■	■
Approvals								
CE		●	●	●	●	●	●	●
UL 21), cUL, CSA		●	●	●	●	●	●	●
GOST R		●	●	●	●	●	●/-	●
C-Tick		●	●	-	-	-	-	-
Marine		● 22)	●	●	●	●	●	●
Auxiliary option kits								
Fuses, fuse bases		-	-	■	■	■	■	■
DC-fuse switch		-	-	-	-	■	-	-
Contactors or breakers		-	-	■	■	-	■	■
Assembly kits for Rittal TS8 cabinets		-	-	■	■	■	■	■
IP21 - IP54 door / roof kits		-	-	■	■	■	■	■

- Standard
- Option built-in
- X External accessory, with plus code
- External accessory, no plus code
- ACS800-04M option
- Not available

- 1) R7 frame size -04M: bottom exit version (+H352) has only wall mounting possibility.
- 2) Only in standard control program.
- 3) Option in ACS800-04M.
- 4) Not available for all variants.
- 5) Software compatibility with different option modules must be checked from ACS800 software compatibility (doc no. 64638211) in ABB Library.
- 6) Only in standard software.
- 7) Not for 690 V.
- 8) Standard in frame sizes R2 and R3 and at 690 V also in R4.
- 9) Fixed I/O in ISU and DSU.
- 10) Frame sizes R2i-R7i.

- 11) Frame sizes R2i to R5i inside of the module.
- 12) Frame sizes R8i-4xR8i D3-5xD4.
- 13) Optional in frame sizes R2i to R7i and 400 V/500 V R8i.
- 14) Not in frame size D3.
- 15) R8i-4xR8i.
- 16) R6 frame size: +E210.
- 17) R6 frame size only.
- 18) Standard in frame sizes nxR8i and R8i 690 V. Optional in frame sizes R7i (400 V, 500 V, 690 V) and R8i (400 V, 500 V).
- 19) Frame size R7i.
- 20) Not for -0205-3 and -0255-5.
- 21) Excluding TSU.
- 22) Type approval (ABS, DNV, Lloyd's, Bureau Veritas)

Summary of features and options

Power and voltage range	Ordering code	04LC	104LC (INU)	204LC (ISU)	304LC and 704LC (DSU)
		Frame sizes D3+R8i to 2xD4+4xR8i	Frame sizes R2i to 4xR8i	Frame sizes R8i to 4xR8i	Frame sizes D3 to 2xD4
		400 V: 200 to 2000 kW 500 V: 315 to 2240 kW 690 V: 400 to 2240 kW	400 V: 1.1 to 2000 kW 500 V: 1.5 to 2240 kW 690 V: 5.5 to 2240 kW	400 V: 180 to 2066 kW 500 V: 208 to 2370 kW 690 V: 191 to 2181 kW	400 V: 303 to 2100 kW 500 V: 303 to 2117 kW 690 V: 522 to 3652 kW
Mounting					
Cabinet mounting		■	■	■	■
Separate drive control unit (RDCU)		●	● 1)	●	●
Cablings					
Supply bottom entry (module terminals)		●	–	–	●
Supply top entry (module terminals)		–	●	●	–
Bottom exit (module terminals)		●	●	–	–
Side exit (module terminals)		–	–	–	–
Top exit in the module		–	–	●	●
Enclosure class					
IP00 (UL open chassis)		●	●	●	●
Motor control					
DTC		●	●	●	–
Software					
Start-up assistant		● 2)	● 2)	●	●
Adaptive programming		●	●	●	–
Optional software optimized for different applications or for enhanced programmability: for more details see section "Application software and programming"		□	□	–	–
Control panel					
Alphanumeric 4*20 character control panel		■	■	■	■
Control panel mounting platform		■	■	■	■
Control connections (I/O) and communications					
3 pcs analog inputs, programmable, galvanically isolated		●	●	● 3)	● 3)
2 pcs analog outputs, programmable		●	●	● 3)	● 3)
7 pcs digital inputs, programmable, galvanically isolated - can be divided into two groups		●	●	● 3)	● 3)
3 pcs relay outputs, programmable		●	●	● 3)	● 3)
Possibility for external control voltage		●	●	●	●
Built-in I/O extension and speed feedback modules: for more details see section "Control connections and communications"		□	□	–	–
Built-in adapters for several fieldbuses: for more details see section "Control connections and communications"		□	□	□	□
Line filter					
AC or DC choke		●	–	–	●
LCL		–	–	●	–
Output filters					
Common mode filter		●	● 4)	● 3)	–
du/dt filters		●	● 5) ■ 6) □ 7)	–	–
Braking					
Brake chopper		■	■	–	–
Brake resistor		–	–	–	–
Regenerative braking		–	–	●	–
Rectifier bridge					
6-pulse that can be connected as 12-pulse		● 8)	–	–	● 8)
Safety					
Prevention of unexpected start-up	Q950	□	□	–	–
Safe torque-off	Q967	□	□	–	–
Approvals					
CE		●	●	●	●
UL, cUL, CSA		●	●	●	●
GOST R		●	●	●	●
Marine		● 9)	● 9)	● 9)	● 9)
Auxiliary option kits					
Fuses, fuse bases		■	■	■	■
DC-fuse switch		–	–	–	–
Contact or breaker		■	–	■	■
Assembly kits for Rittal TS8 cabinets		■	■	■	■

- Standard
- Option built-in
- External accessory, no plus code
- Not available

- 1) Frame sizes R2i-R5i inside of the module.
- 2) Only in standard control program.
- 3) Fixed I/O in ISU and DSU.
- 4) Not for 690 V.
- 5) For frame size nxR8i only.
- 6) For frame size R2i to R5i only.
- 7) For frame size R7i only.
- 8) For frame size D4 only.
- 9) Type approval (ABS, DNV, Lloyd's)

Services

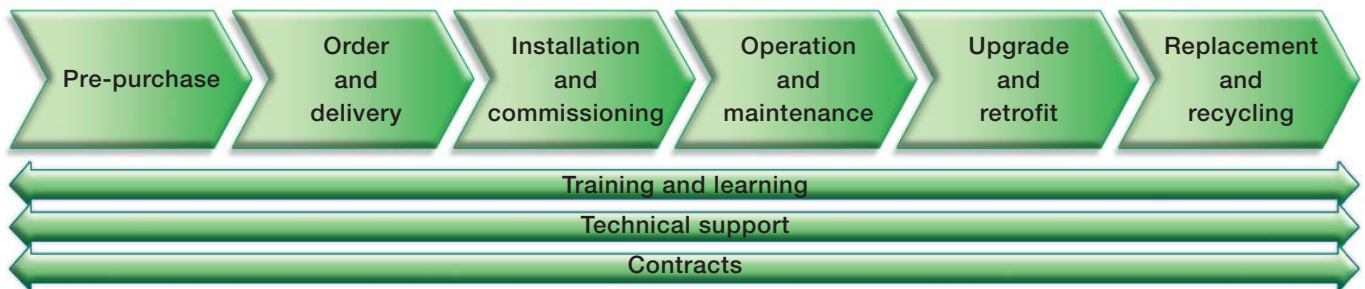

All industries face a common goal: to maximize their production output at the lowest possible cost, while maintaining the highest quality end products. One of ABB's key objectives is to maximize the uptime of its customers' processes by ensuring optimum lifetime of all ABB products in a predictable, safe and low cost manner.

The services offered for ABB low voltage drives span the entire value chain, from the moment a customer makes the first inquiry through to disposal and recycling of the drive. Throughout the value chain, ABB provides training and learning, technical support and contracts. All of this is supported by one of the most extensive global drive sales and service networks.

Maximizing return on investment

At the heart of ABB's services is its drive life cycle management model. All services available for ABB low voltage drives are planned according to this model. For customers it is easy to see which services are available at which phase.

timing of the part replacements plus all other maintenance related actions. The model also helps the customer when deciding about upgrades, retrofits and replacements.

Drive specific maintenance schedules are also based on this four-phase model. Thus, a customer knows precisely the

Professional management of the drive's life cycle maximizes the return on any investment in ABB low voltage drives.

ABB drive life cycle management model



ABB follows a four-phase model for managing drive life cycles, which brings enhanced customer support and improved efficiency.

Examples of life cycle services are: selection and dimensioning, installation and commissioning, preventive and corrective maintenance, remote services, spare part services, training and learning, technical support, upgrade and retrofit, replacement and recycling.

Notes

Contact us

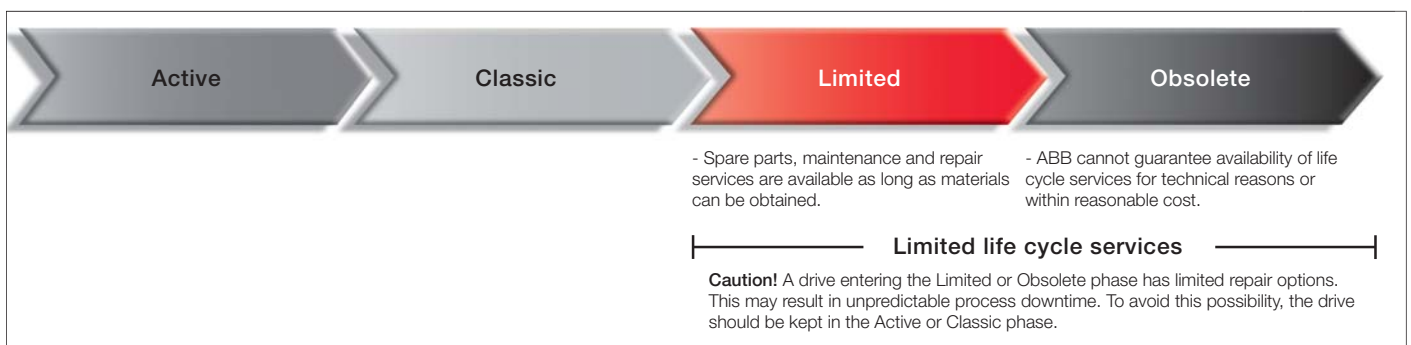
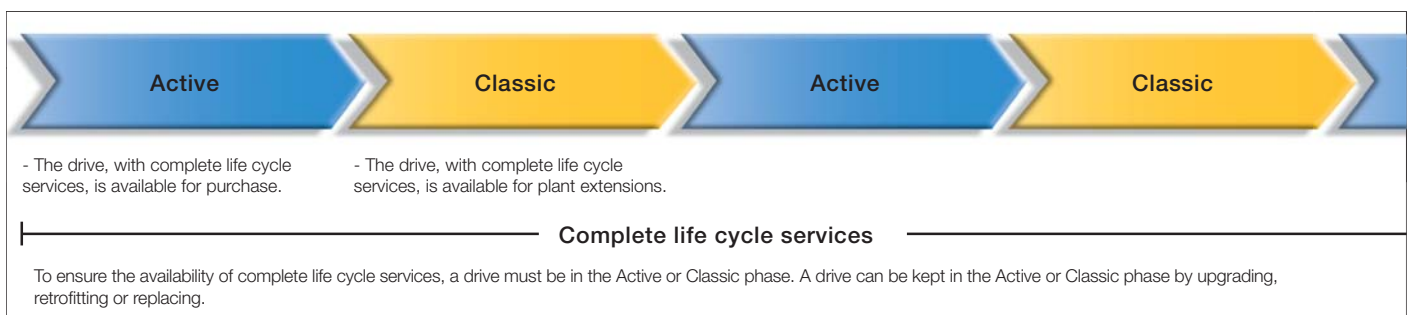
www.abb.com/drives
www.abb.com/drivespartners

© Copyright 2010 ABB. All rights reserved.
Specifications subject to change without notice.

3AFE68404592 REV J EN 20.12.2010 #15380